

e210R

ELECTRIC COMPACT EXCAVATOR



GREEN MACHINE[®]
An  Company



www.greenmachineco.com

e210R PRODUCT FEATURES & SPECIFICATIONS

OPERATING PERFORMANCE

Operating Weight	2,370 lb	(1,075 kg)
Max. Bucket Breakout Force	2,518 lb	(1,142 kg)
Max. Arm Digging Force	1,439 lb	(653 kg)
Arm Length	2 ft 10.6 in	(880 mm)
Slew Speed	10.0 rpm	
Traction Force	2,878 lb	(1,305 kg)
Ground Pressure	4.1 psi	
Max. Travel Speed		
Low Range	1.2 mph	(2 km/hr)
High Range	2.3 mph	(3.7 km/hr)

HYDRAULIC

Total Hydraulic Flow	5.9 gal/min	(22.2 L/min)
Auxiliary Hydraulic Flow	5.9 gal/min	(22.2 L/min)
System Operating Pressure	2,680 psi	(18.2 mpa)

MOTOR

Horsepower @ 3500 rpm	23.1 hp	(17.2 kW)
Torque @ 0 rpm	40.3 ft-lb	(54.6 Nm)

FLUID CAPACITIES

Hydraulic Reservoir Capacity	2.3 gal	(9.0 L)
Hydraulic System Capacity	4.0 gal	(15.0 L)



DUAL SIDE ENTRY

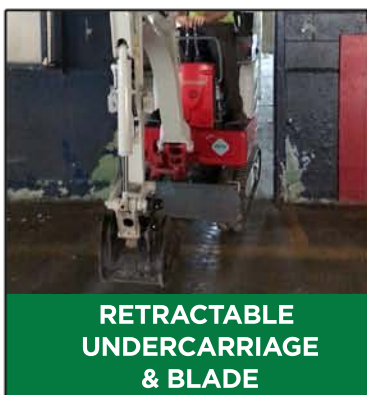

RETRACTABLE UNDERCARRIAGE & BLADE



MINIMAL TAIL SWING



FOLDABLE ROPS

ENGINE

- Zero Emissions
- 3-Phase AC Brushless
- Variable Frequency Drive
- Dial Operated Electronic Speed Control
- Flat Torque Curve from 0 RPM

BATTERY

- High Capacity Lithium Ion
- 12.8 kWh
- Sophisticated Battery Management System
- Stainless Steel Case
- Waterproof/Dustproof

ELECTRICAL

- Battery Level Display
- 12 Volt System With 15 Amp DC-DC Converter
- Boom Mounted Work Light
- Travel Alarm
- Hour Meter

UNDERCARRIAGE & FRAME

- Hydraulically Retractable Track Frame
- Low and High Range Travel
- Back II Blade with Pin-on Extensions
- Protective Counterweight

HYDRAULIC

- Pilot Operated Joystick Controls
- Tandem Gear Pumps
- Auxiliary Hydraulic Circuit Plumbed to Arm
- Selectable One-way and Two-way Auxiliary Operation
- Pilot Accumulator
- Hydraulic Tank with Fluid Level Sight Gauge
- Foot Controlled Auxiliary Hydraulics with Detent for Hand Tools

WORKING EQUIPMENT

- Top Mount Boom Cylinder
- Minimal Tail Swing
- Long Arm
- Hydraulics Lines Protected in Boom and Arm
- Boom Swing 850 Left & Right
- Cushioned Boom Cylinder
- Dual Pin Position Bucket (optional)

OPERATOR'S STATION

- ROPS / TOPS Two Post Foldable Frame
- Pattern Change Valve
- Foot Controlled Auxiliary Hydraulics
- 2" Retractable Seat Belt

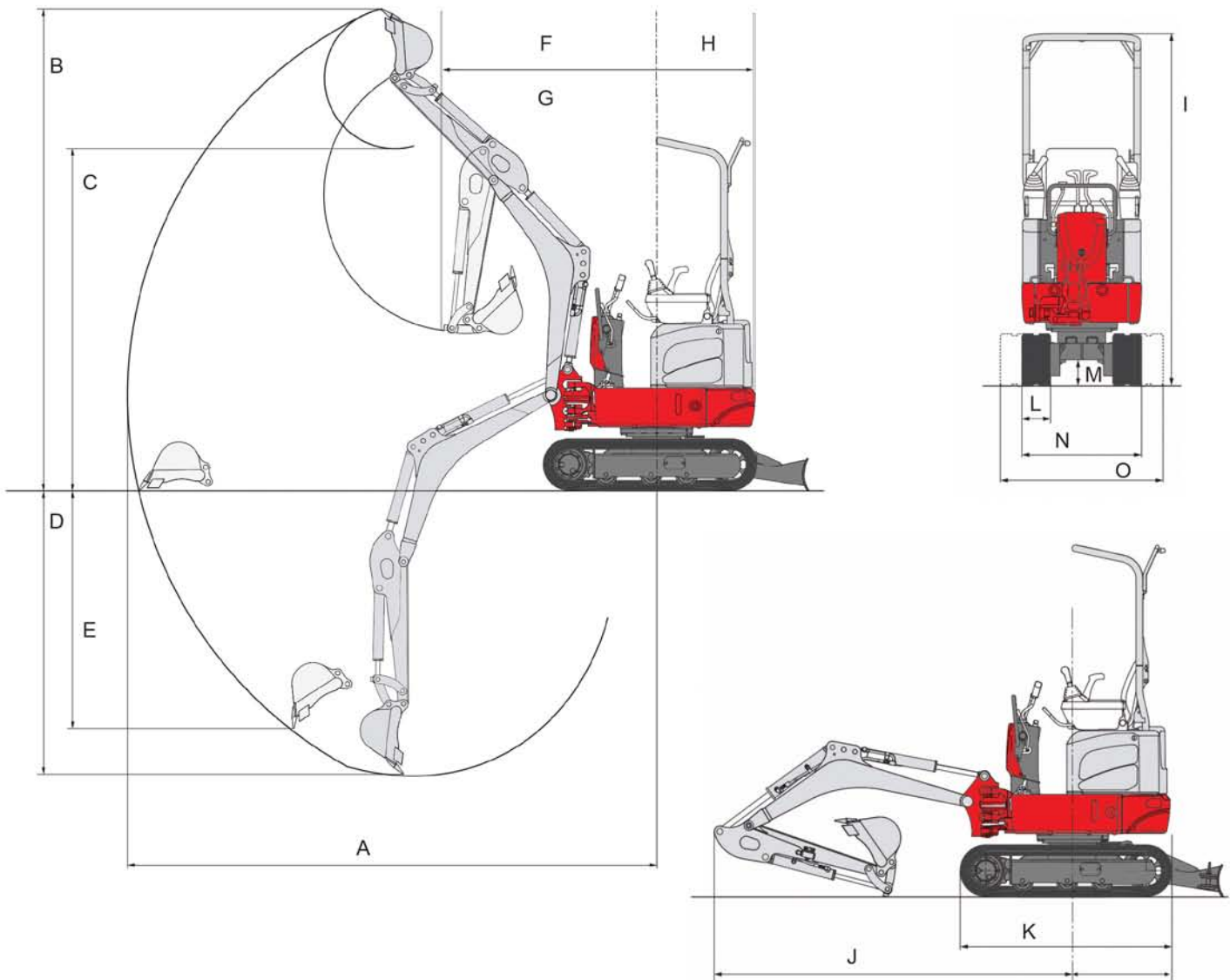

MACHINE DIMENSIONS

A	Maximum Reach	10 ft 9.4 in	(3,285 mm)
B	Maximum Dig Height	9 ft 9.5 in	(2,985 mm)
C	Maximum Dump Height	6 ft 11.5 in	(2,120 mm)
D	Maximum Dig Depth	5 ft 9.1 in	(1,755 mm)
E	Maximum Vertical Dig Depth	4 ft 10 in	(1,475 mm)
F	Front Swing Radius	4 ft 4 in	(1,320 mm)
G	Front Swing Radius (Offset)	3 ft 2.5 in	(980 mm)
H	Tail Swing Radius	2 ft 0 in	(610 mm)
I	Transport Height	7 ft 2.6 in	(2,200 mm)
J	Transport Length	9 ft 8.3 in	(2,955 mm)
K	Undercarriage Length	4 ft 4.2 in	(1,325 mm)
L	Track Width	7.1 in	(180 mm)
M	Ground Clearance	6.2 in	(157 mm)
N	Track Width Retracted	29.5 in	(750 mm)
O	Track Width Extended	40.2 in	(1,020 mm)



EXCELLENT SERVICEABILITY



PATTERN CHANGE VALVE



FOLDABLE FOOT PEDALS



TWO-SPEED TRAVEL

The e210R features many upgrades that will enhance operator comfort, efficiency, and serviceability. To improve fine control and reduce fatigue, the e210R now features pilot operated joystick controls that are low effort and responsive to operator input.

Additionally, an ISO/SAE pattern change valve has been added enabling the operator to choose their preferred operational pattern. The boom cylinder is now mounted on top of the boom for greater protection and improved

routing of the hydraulic lines which are run through the boom and arm. A hydraulically retractable track frame and the addition of a foldable ROPS frame allow it to easily pass through a standard doorway.

To reduce the likelihood of rear swing impacts, the e210R also features a short tail swing design. Despite its compact dimensions, service access is exceptional thanks to the tilt-up seat pedestal and access panels.



SPACIOUS OPERATOR'S STATION WITH NEW PILOT OPERATED JOYSTICKS