



JCB ELECTRIC COMPACT EXCAVATOR 19C-1E



DISCLAIMER

This Quick Reference Guide is to provide quick and simple information to the Operator and does not include any health and safety aspects. In addition, because of our continual development of machines, features described in this Quick Reference Guide may differ from those on your machine. No errors and omissions can be entirely ruled out.

This Quick Reference Guide DOES NOT replace the Operators Manual. You MUST read ALL the disclaimers and safety and other instructions in the Operators Manual before initially operating this product. Accordingly, no legal claims can be entertained on the basis of the data, illustrations or descriptions in this Quick Reference Guide.

This machine should not be operated by any person who isn't appropriately qualified or had the appropriate training.

Operation of this machine without periodic maintenance could cause it to malfunction. For more information please contact your JCB Dealer.



WARNING: This machine uses a 48V electrical powertrain system. **DO NOT** work on this machine unless you are suitably trained, competent and authorised to carry out work in a safe and controlled manner.

INDEX

Intended Use	4
Electrical Powertrain Specification	5
Dimensions	6
Dig Performance	7
Tie Down Points	8-10
Lifting Points	11
Cab & Control Layout	12-14
Instrumentation Panel	14
Hydraulic Control Layout	15
Start Up Sequence	16
Hitch Unlock Sequence	17-18
Auxiliary Venting & Shutdown	19
Charging Levels & Charging	20
Maintenance Position	21
Service / Maintenance Schedule	22
Access Covers	23-24
Fluids & Lubricants	25
Machine Attachments	26
Troubleshooting / FAQs	27-28

INTENDED USE

General

- Machine Type – Compact Excavator
- Self propelled machine with a tracked undercarriage
- 360° revolving upper structure with boom, dipper, bucket and slew mechanism

Intended Use

- Machine intended to be used in normal conditions as detailed in the operators manual
- With bucket fitted, machine work cycle consists of digging, elevating, slewing and discharging of materials
- Applications include earthmoving, road construction, building and construction, landscaping and indoor areas etc.
- Can be used for object handling if fitted with relevant parts and systems
- Not intended for use in mining and quarrying applications, demolition, forestry and any explosive atmospheres
- Must not be used for forestry, used with attachments of unknown weight, used on surfaces with unknown stability – list not exhaustive
- PPE may be required in certain applications/environments e.g. high silica concentration or asbestos
- The machine should not be operated by any person without appropriate qualifications, training or experience of using this type of machine
- Prior to use, the machines suitability should be considered with regards to the intended applications and any hazards which may be present

ELECTRICAL POWERTRAIN SPECIFICATION

Battery Type	Manganese laminated Lithium-ion
Battery Rated Capacity	14.8 kWh (3 Pack) 19.8 kWh (4 Pack)
System Voltage	48V
Motor Type	AC permanent magnet
Motor Power	7 kW continuous 20kW peak
Charging	On-board charger with direct connection from AC mains power supply
Charging Time	110V – 12 hrs 230V – 8 hrs
Fast Charging (Optional)	Off-board charger, with connection to 415V 3-Phase supply Charging time <2 hrs
Thermal Limitations	Operation: -10°C to +46°C Charging: -10°C to +40°C
Operating Modes	L – 1200rpm G – 1600rpm H – 1800rpm Auto Kick Up – 2300rpm, 2 speed tracking only

DIMENSIONS

Fig. I

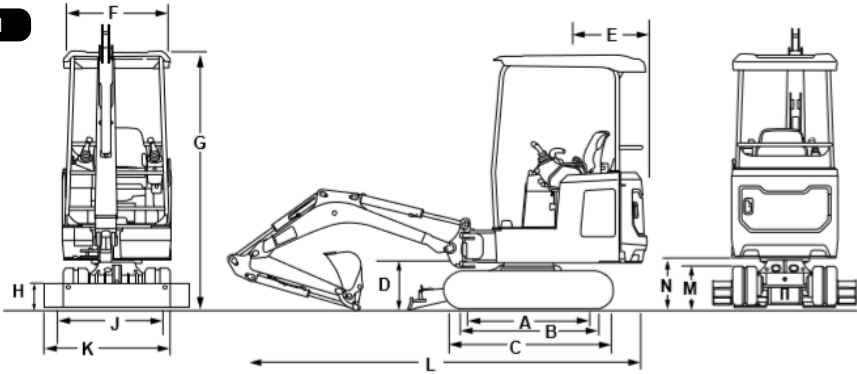

Description		19C-IE
A	Sprocket idler centres	mm 1218
B	Track length on ground	mm 1220
C	Undercarriage overall length – rubber	mm 1578
	Undercarriage overall length – steel	mm 1578
D	Kingpost clearance	mm 409
E	Tail swing radius	mm 1103
F	Overall width of superstructure	mm 996
G	Height over cab	mm 2324
H	Ground clearance	mm 162
J	Track gauge – Retracted	mm 750
	Track gauge – Extended	mm 1110
K	Width over tracks – Retracted	mm 980
	Width over tracks – Extended	mm 1330
L	Transport length- 950mm dipper	mm 3860
	Transport length – 1,100mm dipper	mm 3862
	Transport length – 1,344mm dipper	mm 3815
M	Track height	mm 367
N	Counterweight clearance	mm 434
	Operating weight*	kg 1862

* Standard machine specification, please see data plate for specific machine weight

DIG PERFORMANCE

Fig.2

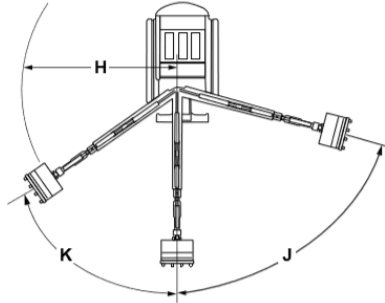
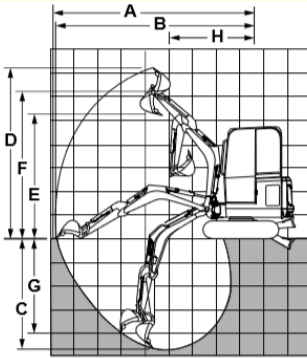

Description		19C-1e	
Boom length	mm	1800	
Dipper length	mm	1100	
A	Maximum digging reach	mm	4043
B	Maximum digging reach on ground	mm	3981
C	Maximum digging depth – dozer up	mm	2421
	Maximum digging depth – dozer down	mm	2576
D	Maximum digging height	mm	3667
E	Maximum dump/load-over height	mm	2637
F	Maximum height to dipper nose pivot pin	mm	3335
G	Maximum vertical wallcut depth	mm	2534
H	Minimum front swing radius (no offset)	mm	1517
	Minimum front swing radius (fully offset)	mm	1196
J	Boom swing left	°	75
K	Boom swing right	°	55
	Bucket rotation	°	201
	Dipper rotation	°	126
	Bucket tearout (power position)	kN	18

TIE DOWN POINTS

When transporting the machine one of the following two methods should be used:

Method 1

Fig. 3

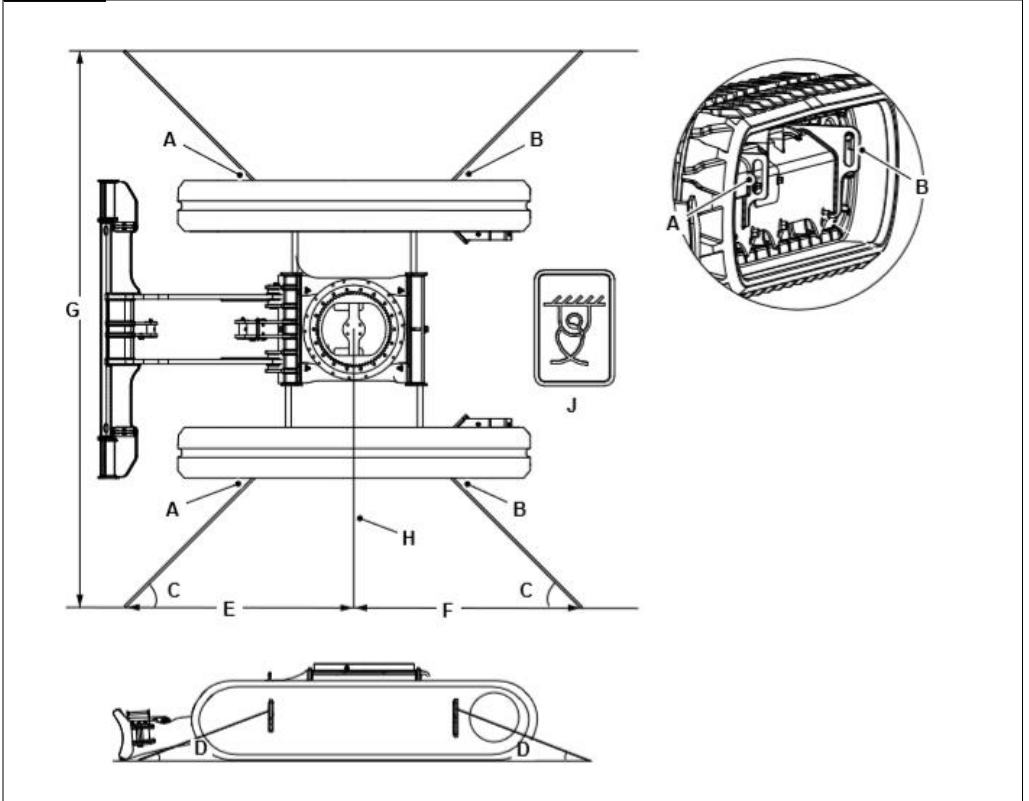

A – Front undercarriage track leg tie-down points

C – Angle = 25° to 45°

E – Length = 1,723mm to 1,027mm

G – Length = 2,500mm

J – Tie down decal

B – Rear undercarriage track leg tie-down points

D – Angle = 9° to 15°

F – Length = 1,726mm to 1,023mm

H – Slew ring centre line

TIE DOWN POINTS

Method 2

Fig. 4

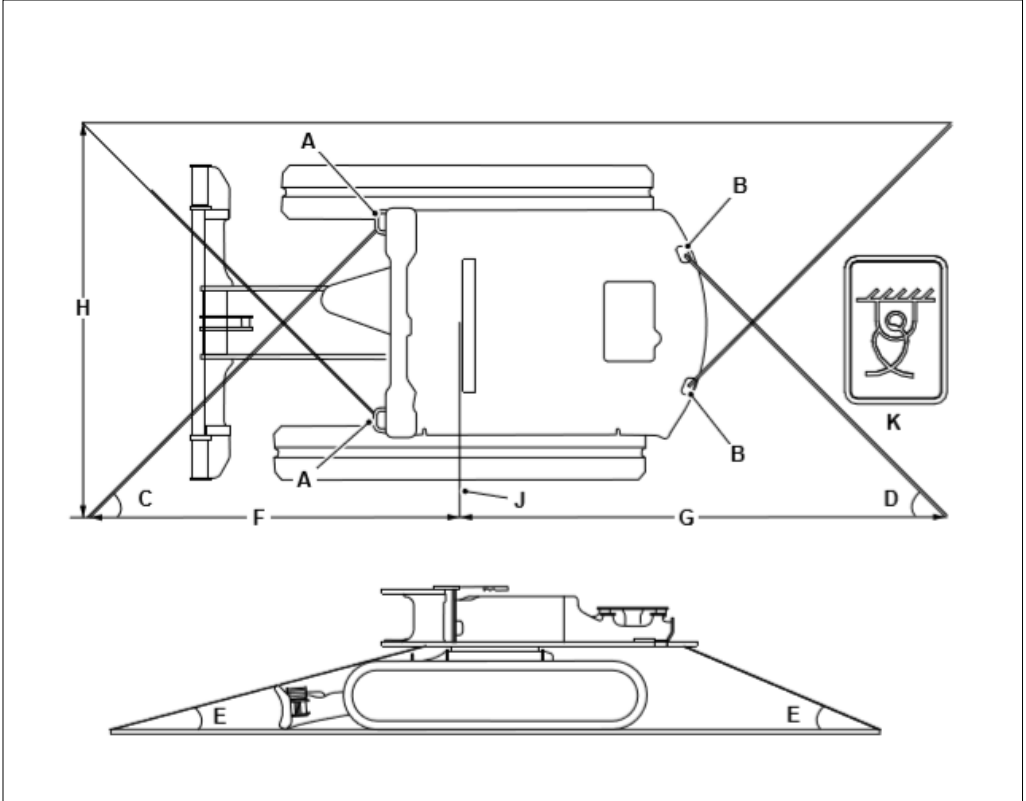

- A** – Front slew spine tie-down point
- C** – Angle = 35° to 46°
- E** – Angle = 9° to 15°
- G** – Length = 2,720mm to 1,943mm
- J** – Slew ring centre line

- B** – Rear slew spine tie-down point
- D** – Angle = 45° to 50°
- F** – Length = 2,499mm to 1,846mm
- H** – Length = 2,500mm
- K** – Tie down decal

TIE DOWN POINTS

Method 3

Fig. 5

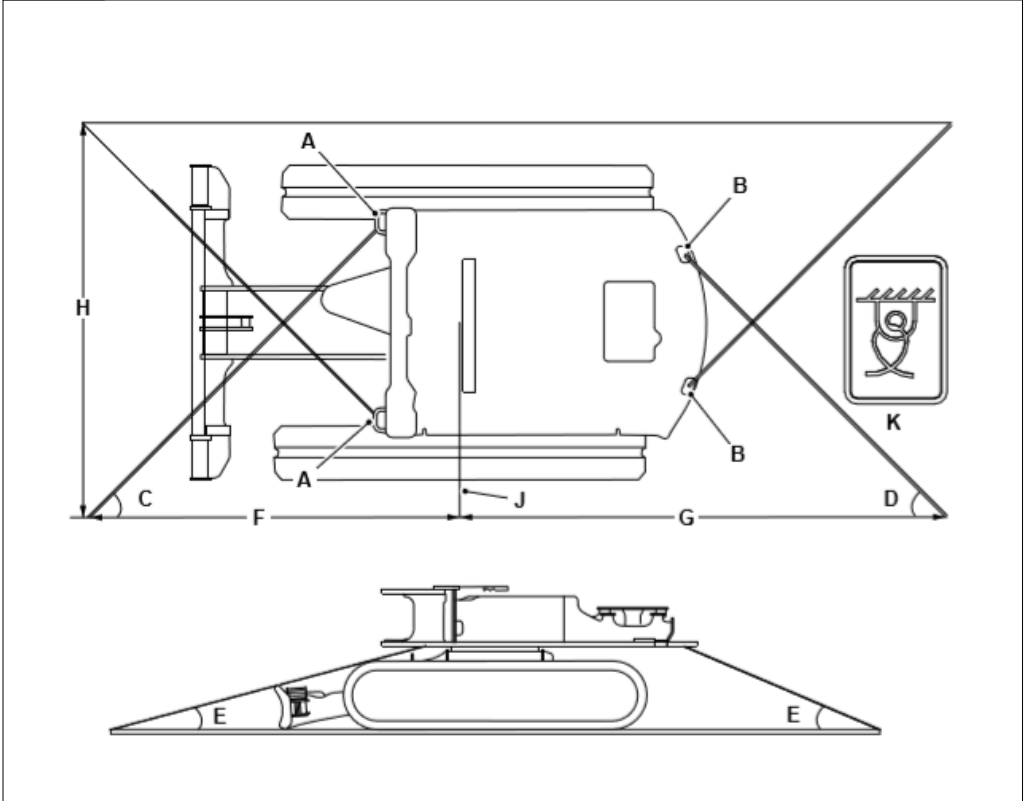

- A** – Front slew spine tie-down point
- C** – Angle = 35° to 46°
- E** – Angle = 9° to 15°
- G** – Length = 2,282mm to 1,670mm
- J** – Slew ring centre line

- B** – Rear slew spine tie-down point
- D** – Angle = 35° to 45°
- F** – Length = 2,499mm to 1,846mm
- H** – Length = 2,500mm
- K** – Tie down decal

LIFTING POINTS

Fig. 6

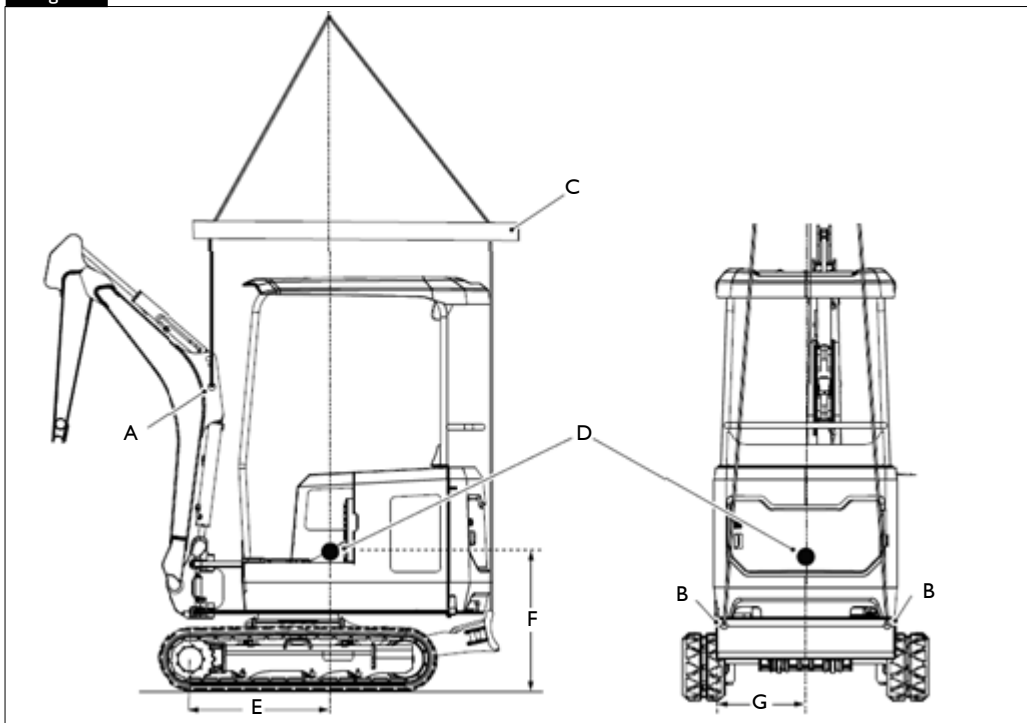

Description		I9C-1e
A		Boom Lift Point
B		Dozer Blade Lift Point
C		Spreader Bar
D		Centre of Gravity
E	mm	817
F	mm	786
G	mm	528

The correct lifting positions are identified on the machine by their labels:

Fig. 6



LIFTING POINT
POSITION
LABEL

CAB & SWITCH PANEL

Operator Station Layout

Fig. 7

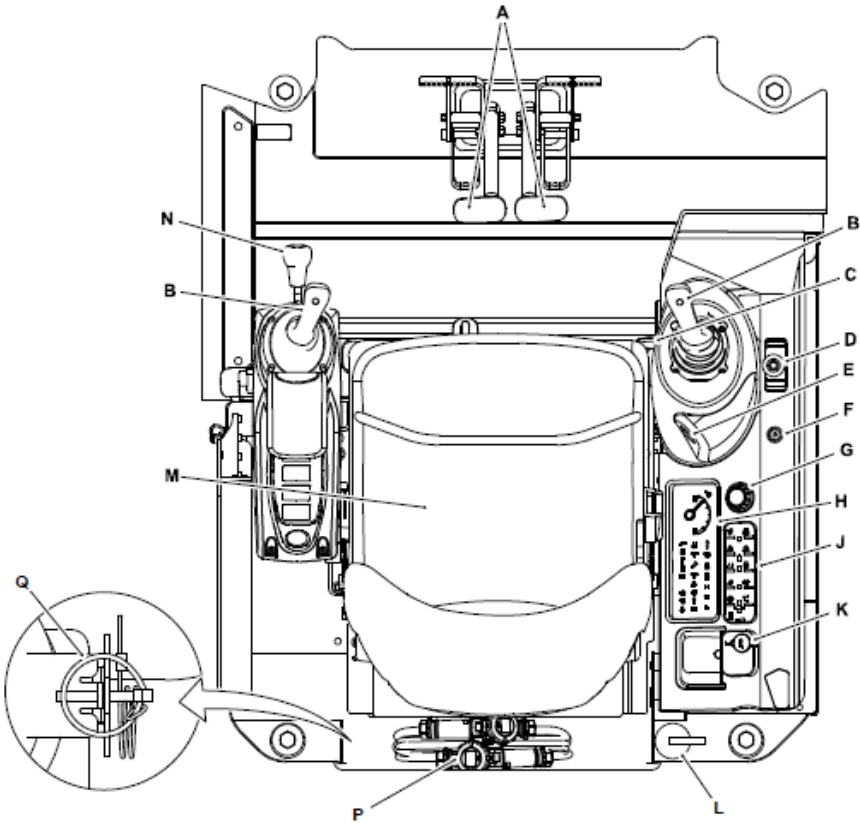

- | | |
|---|--|
| A – Track controls | B – Control lever |
| C – Track extension lever | D – Dozer blade control lever |
| E – Ignition switch | F – Motor running indicator light |
| G – Rotary hand throttle control | H – Instrument panel |
| J – Console switch panel | K – Auxiliary power socket |
| L – Fire extinguisher | M – Operator seat |
| N – Control isolation lever | P – Charging cable stowage |
| Q – Quickhitch release bar stowage | |

CAB & SWITCH PANEL

Switch Panel

Fig. 8



Work Lights

- 1 = Off
- 2 = On (Boom)
- 3 = On (Boom & Cab)



Beacon

- 1 = Off
- 2 = On



Window Wipers

- 1 = Off
- 2 = Intermittent / continuous / washer



Controls Isolation (2GO)

- 1 = Off
- 2 = Activate/de-activate hydraulic controls



Bi-Directional and Hammer Mode Selector

- 1 = Bi-directional mode – Double acting 2
- = Hammer mode – Single acting

Fig. 9

- A – Control Isolation Switch (2Go)
- B – Aux 1 selection switch
- C – Lift overload switch on/off switch
- D – Worklights on/off switch
- E – Wiper/ washer on
- F – Auto-hydraulic warming switch
- G – H+ mode selection switch
- H – Aux 2 selection switch
- J – Auto idle on/off switch
- K – Beacon on/off switch
- L – Q-hitch sequence switch

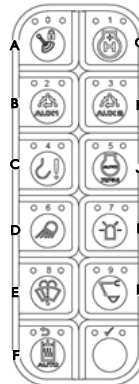

Key

Black Text – Standard equipment
 Blue Text – Not Used

INSTRUMENT PANEL

Instrument Panel – I9C-IE

Fig. 10

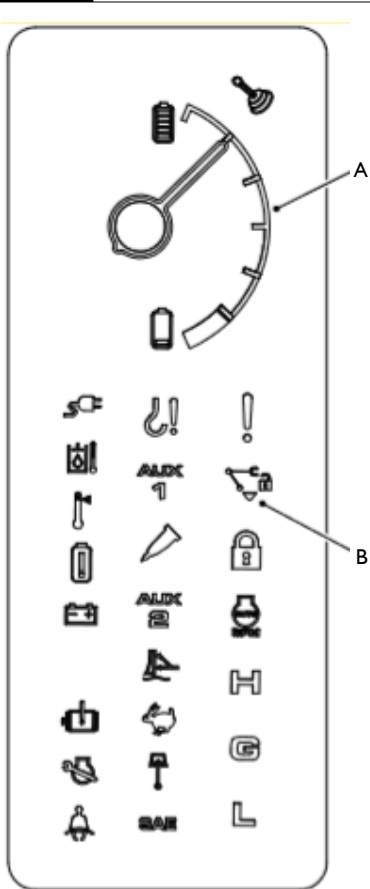

A – Battery level indicator gauge
B – Warning and indicator lamps

Fig. 11

- | | | | |
|--|--------------------------------|--|--------------------|
| | Charger connected | | Dozer float |
| | Hydraulic oil-over temperature | | High speed travel |
| | System over temperature | | Swing active |
| | Li- ion battery system | | SAE active fault |
| | 12V battery charging | | Master warning |
| | Motor fault | | Immobiliser active |
| | Service due | | Hydraulics active |
| | Seat belt | | Quick hitch unlock |
| | Lift overload warning | | Auto idle active |
| | Aux 1 – double acting | | 'H' mode active |
| | Aux 1 – single acting | | 'G' mode active |
| | Aux 2 – low flow | | 'L' mode active |

JOYSTICK & DOZER LEVER

Swing Controls

Fig. 12

- A – Swing left
- B – Swing right
- C – Swing thumb wheel control
- D – Change over button

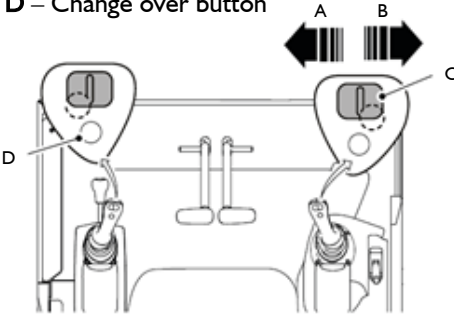

Auxiliary Controls

Fig. 13

- A – Tilt/grab changeover for tilt-rotator
 - B – Boom swing/Aux change over button
 - C – Thumb wheel control – Aux 2 (Low flow)
 - D – Continuous flow button – Hammer circuit
 - E – Thumb wheel control – Aux 1 (High flow)
- Note: A & D located underside of joystick

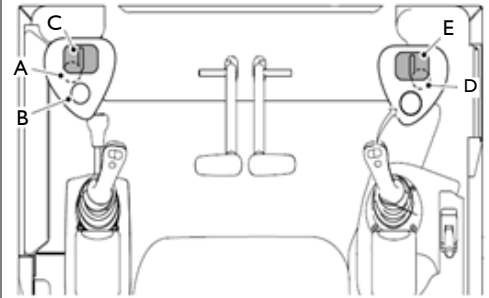

Dozer Lever

Fig. 14

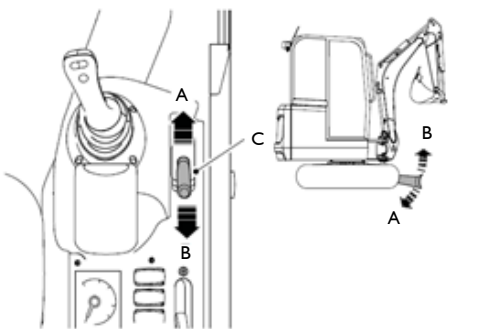

- A – Lower the dozer
- B – Raise the dozer
- C – Control lever

Retracting Undercarriage Lever

Fig. 15

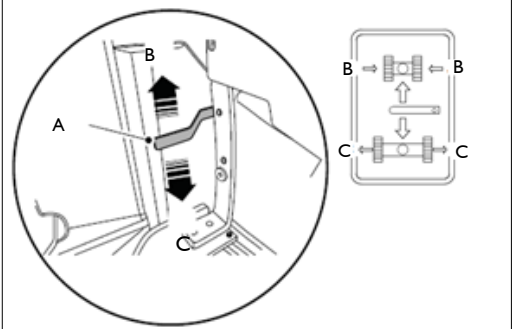

- A – Track Extension Lever
- B – Upward - Retract
- C – Downward - Extend

START UP SEQUENCE

1 Raise Pod Arm

Ensure the hydraulic isolation lever (left hand arm rest) is in the raised position.

- A – Handle
- B – LH arm rest

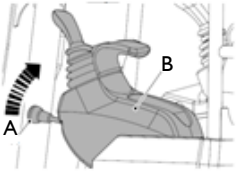

2 Engage Seat Belt

Engage seat belt (A) into latch (B) before starting machine.

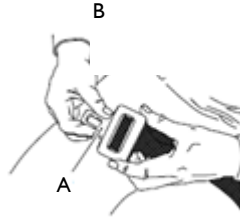

3 Power Machine On

Insert key in to ignition switch, and turn to position I. The instrument panel will illuminate.

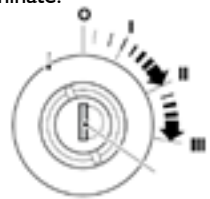

4 Disarm Immobiliser

If fitted, disarm by entering PIN code using the switch panel buttons. Confirm code by pressing the tick button.

Note: switch panel buttons will all be illuminated red and instrument panel will display a padlock symbol if immobiliser is fitted and armed

5 Start Motor

Turn key in ignition switch to position III and hold until the motor running indicator light illuminates.



6 Lower LH Arm Rest

Lower the LH arm rest to activate the hydraulics.

Note: If 2 GO enabled go to step 8, if not go to step 9

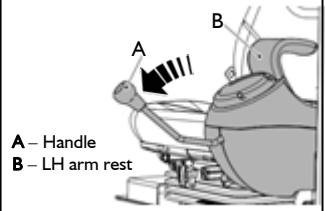

7 Press 2 GO Button

If enabled press 2 GO button (A) to activate hydraulics. Instrument panel will illuminate (B) when active.

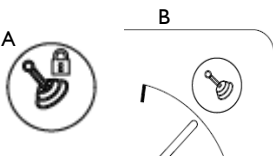

8 Operate Machine

All controls are now active and the machine is now ready to use.

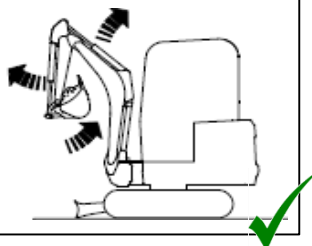

HYDRAULIC HITCH UNLOCK SEQUENCE

Standard Attachments

1 Start Unlock Process

To start quick hitch unlock process ensure hydraulics are live then press quick hitch sequence button (A).



2 Confirm Process

Instrument panel will indicate need to confirm process (A). To confirm process press 2 GO button (B).



3 Boom LED Indicator

When the sequence is confirmed the LED on the boom will flash red (A).

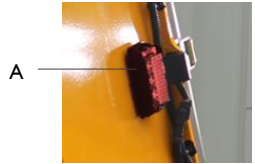

4 Remove Attachment

To disengage the pivot pin, crowd attachment for 3 seconds then remove attachment.



5 Change Attachment

Operate the machine to engage the jaw (A) with the attachment (B) and then full crowd the attachment to align latch.

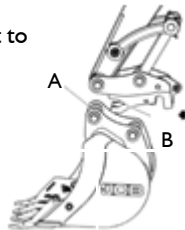

6 Lock Quick Hitch

To engage the lock on the quick hitch press one of the following two buttons and visually check hitch is locked.



MECHANICAL HITCH UNLOCK SEQUENCE

Standard Attachments

1 Park Machine Up

Park the machine on firm level ground. Position the attachment (A) just above the ground and dozer (B) on the ground.

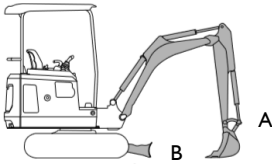

2 Disconnect Attachment

Stop the motor, remove any connected hydraulic hoses and remove the locking pin.

3 Insert tommy bar

Insert the tommy bar into the hole of the latch hook.

A – Latch Hook C – Hole
B – Tommy Bar

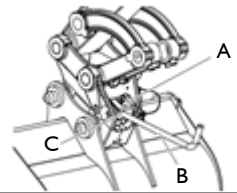

4 Release Attachment

Apply downward pressure to the tommy bar to release the buckets rear pivot.

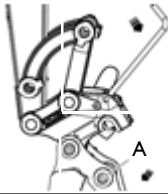

5 Restart Machine

Start the motor, rest attachment on the ground and engage the hydraulics.

6 Remove Attachment

Slowly roll the quickhitch in the direction of the arrow whilst raising the dipper to release the front pivot (A).

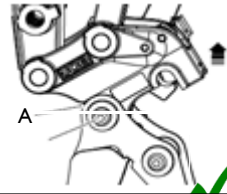

SHUTDOWN & AUXILIARY VENTING

Auxiliary Venting (Within 1 Minute of Motor Shutdown)

1 Lower LH Arm Rest

While sitting in the operating station with motor off lower LH arm rest.

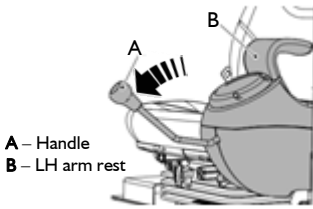

2 Machine Power On

Turn ignition switch to position 1 so that the instrument panel and switches become active (enter immobiliser code if requested).

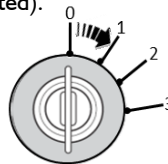

3 Press 2 GO Button

Press 2 GO button (A) to activate hydraulics. Instrument panel will illuminate (B) when active.

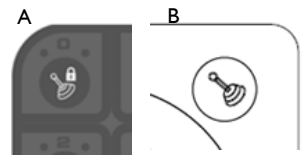

4 Select Aux Circuit

Enable aux function on top of the left control lever (A). Ensure symbol (B) or (C) is displayed.



5 Switching Circuits

Change Aux mode between Aux 1 (A) and Aux 2 (B) using mode select switch on the right hand console.

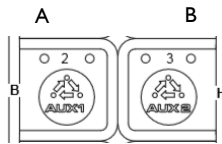

6 Venting Aux Circuit

Operate the roller switch fully in both directions to release stored pressure. Right hand (A) for Aux 1 and left hand (B) for Aux.

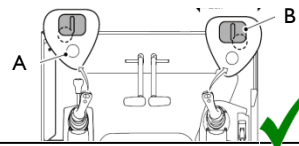

Shutdown Sequence

1 Park Machine Up

Park machine on solid level ground with the attachment (A) and dozer (B) on the ground.

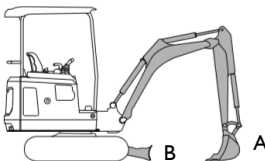

2 Machine Power Off

Turn ignition switch to position 0 and remove the key.

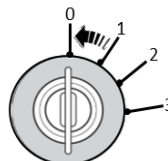

3 Leave & Secure

Switch off all switches. Leave machine using the handrails and footholds. Close & lock all doors and windows to secure machine.



CHARGING LEVELS & CHARGING

Fig. 16

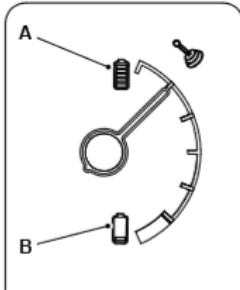

A – Battery full charge indicator
B – Low battery indicator

The machine is charged using the plug on the right hand side, as viewed from the rear of the machine.

Note: there is no requirement for the machine power switch to be turned ON whilst charging.

- 1) Connect the charge lead to the mains supply outlet and to the machine inlet
- 2) Depress the reset button on the inline RCD*
- 3) Green status LED light will illuminate at charge inlet (See (A) in Fig. 17)
 - 1) LED light will pulse when charging
 - 2) LED light will hold green when plugged in and not charging
- 4) Machine instrument panel will illuminate and display state of charge

Fig. 17

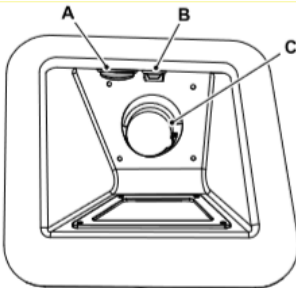

A – Charge indicator LED
B – Operating Status

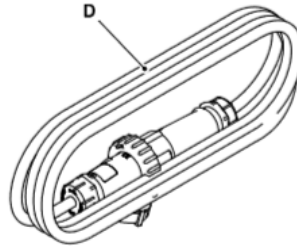

C – Charging socket
D – Charge cable

*for 230V AC mains supply, when using 110V AC, an RCD is not provided

Note: Only use the Genuine JCB Charge Cable supplied with the machine. Use an appropriate grounded industrial supply with correct AC (alternating current) input voltage.

If at any time a fault occurs when charging, the status LED light in Fig. 17 (A) illuminates red, unplug the charging cable and repeat the above steps. If further issues occur, unplug the charging cable and contact your local JCB Dealer. If there is a fault with the power supply the status LED will alternate green and red.

MAINTENANCE POSITION

- I. Park the machine on solid, level ground
 - I. Release the two track levers
 - II. Set the hand throttle dial to the idle position
2. Lower the dozer blade
3. Lower the excavator so the attachment is flat on the ground

Fig. 18

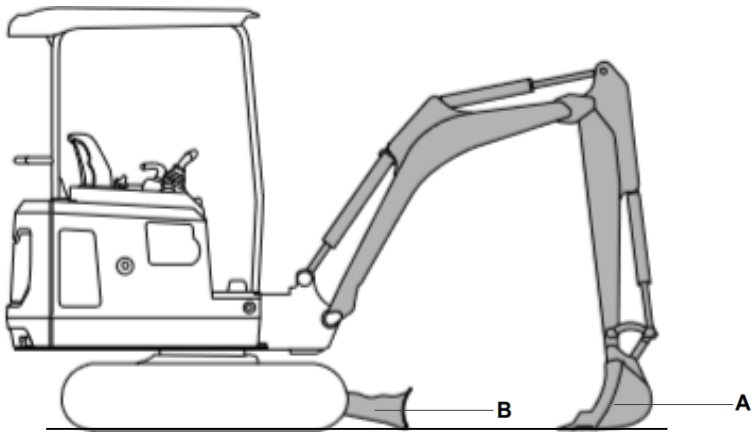

- A** – Attachment flat on the ground
B – Dozer blade lowered to ground

4. Discharge the hydraulic pressure (see aux venting operation)
5. Isolate the controls and remove power switch key

SERVICE / MAINTENANCE

Daily Checks (10h)	Check
Check condition of hydraulic cooling pack and system	Visual Check
Check hydraulic oil level	Visual Check
Check the condition of welded structure	Visual Check
Check condition of bodywork and framework	Visual Check
Check condition of attachments / optional equipment	Visual Check
Grease attachments / optional equipment as required	Lubricate
Check operation of all services i.e. excavator, dozer etc.	Operate
Check operation of all electrical equipment i.e. horn, alarms etc.	Operate
Check the track and running gear operation	Operate
Check operation of the hour meter	Visual Check
Check condition of the charging cable and the inlet connection	Visual Check

Weekly Checks (50h)	Check
Clean hydraulic cooling pack	Clean
Check hydraulic hoses / pipework for leaks and damage	Visual Check
Check condition of the rams	Visual Check
Check the condition of the electrical wiring	Visual Check
Check condition and tension of tracks	Visual Check
Check presence of all pivot pin retaining bolts	Visual Check
Grease slew ring bearing	Lubricate

ACCESS COVERS – SERVICE ITEMS AND RELAYS

Fig. 19

- A – Lock
- B – Service compartment cover
- C – Handle

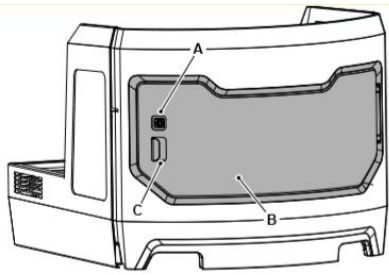

Fig. 20

- A – Fixings
- B – Relay access cover

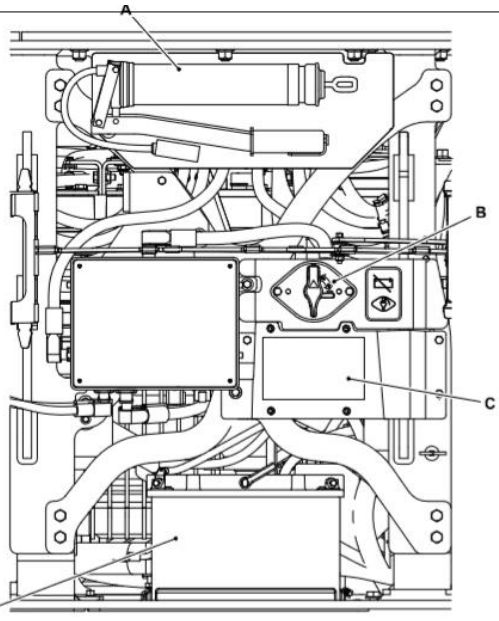

Fig. 21

- A – Grease gun
- B – Service disconnect
- C – Fuse/relay box
- D – 12V Battery

ACCESS COVERS – FLUID LEVELS AND FILL

Fig. 22

- A** – Hydraulic compartment cover
- B** – Lock

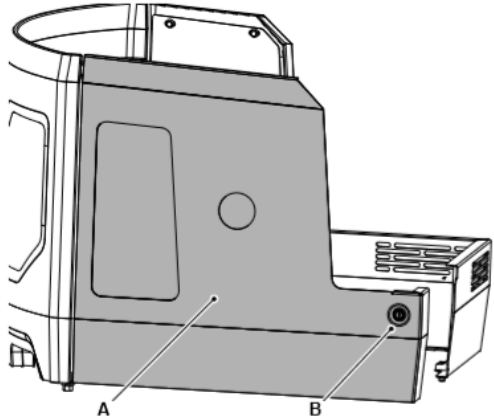
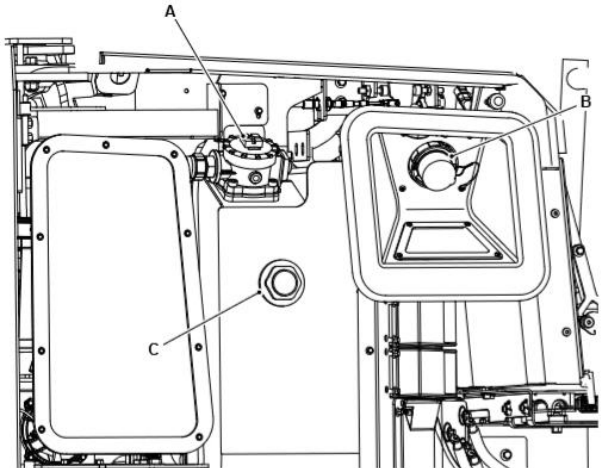

Fig. 23

- A** – Hydraulic tank filler cap
- B** – High voltage batteries charging point
- C** – Hydraulic oil level indicator



FLUIDS & LUBRICANTS

Item	Capacity	Fluid/Lubricant	JCB Part Number	Container Size ⁽¹⁾
Track Gearbox (each)	0.3L	JCB Engine Oil HP SAE 30 (Not Multigrade)	4001/0305	20L
Track Idler Wheels	0.3L	JCB HP90 Gear Oil	4001/0305	20L
Track Rollers (bottom)	0.025L	JCB HP90 Gear Oil	4000/0305	20L
Hydraulic System	28L	-20°C (-4°F) to 46°C (114.7°F): JCB Hydraulic Fluid OP32	4002/1025	20L
Hydraulic Tank	15L	-20°C (-4°F) to 46°C (114.7°F): JCB Hydraulic Fluid OP32	4002/1025	20L
Slew Ring Bearing	As required	JCB HP Grease	4003/2017	0.4kg
Slew Ring Gear Teeth	As required	JCB Special Slew Pinion Grease	4003/1619	0.4kg
All Other Grease	As required	JCB MPL-EP Grease	4003/1501	0.4kg

(1) For information about the different container sizes that are available (and their part numbers), contact your local JCB dealer.

MACHINE ATTACHMENTS

Description	Weight (kg)	Intended Use	Hydraulic Requirements
Mechanical Quickhitch	13.7	Quick change of attachments	None
Hydraulic Quickhitch	22	Quick change of attachments	Quickhitch circuit
Bucket GP 150mm	20.2	General excavation / Bulk loading loose material	None
Bucket GP 230mm	22.2	General excavation / Bulk loading loose material	None
Bucket GP 300mm	24.4	General excavation / Bulk loading loose material	None
Bucket GP 400mm	28.7	General excavation / Bulk loading loose material	None
Bucket GP 460mm	30.3	General excavation / Bulk loading loose material	None
Grading / Ditching Bucket 760mm	36.8	Grading, finishing, landscaping & Ditching	None
Grading / Ditching Bucket 1000mm	44.9	Grading, finishing, landscaping & Ditching	None
Earth Drill – 1500Nm	63.8	Drilling 160mm – 900mm holes	1x Hi-Flow aux service
Breaker – HM1012T	107	Breaking up tarmac, concrete, rock	1x single acting aux service
Breaker –HM100Q	129	Breaking up tarmac, concrete, rock	1x single acting aux service

ATTACHMENT WEIGHTS ARE A GUIDE ONLY, ALWAYS CHECK YOUR OWN ATTACHMENTS



ADDITIONAL ATTACHMENTS

Description	Intended Use
110V Charging Cable	Charging from a 110V supply (IEC60309 110V 16A)
230V Charging Cable	Charging from a 230V supply (IEC60309 230V 16A)
Type E, F (Shuko) 230V Charging Cable	Charging from a 230V supply (Type E, F (Shuko) 230V 16A)

TROUBLESHOOTING / FAQ'S

Issue / FAQ	Resolution / Answer
My machine will not start	<p>Ensure the service disconnect is turned on. Verify the start up sequence has been followed (Page 16).</p> <p>If machine still will not start contact dealer</p>
I can't activate the Hydraulics	<p>Here are some of the possible reasons:</p> <ul style="list-style-type: none"> • When the machine hydraulics are live and you lift the left hand pod you will need to re-select '2-GO' when the pod is returned to the down position. • The left hand pod is in the raised position. • There is a fault on the keypad. • Motor isn't switched on. • If there is an error on the machine and an error code is displayed on the LCD screen – which would inhibit the hydraulics. <p>If hydraulics still won't activate contact dealer</p>
Why is there an audible buzzer in the cab when I'm lifting a large load?	<p>The lift overload warning system has detected a load that is near the limits of the machine, reduce load to prevent machine overturning.</p>
Can I disable the lift overload warning indicator when not object handling?	<p>To disable lift overload warning indicator when not object handling, press button 'C' on the switch panel (refer to page 13).</p>
500hrs Greasing - Does it matter if greased every day?	<p>No, there is no impact on life of the pivot pins or bushes</p>

TROUBLESHOOTING / FAQ'S

Issue / FAQ	Resolution / Answer						
500hrs Greasing - Do the bushes need to be replaced at 500hrs?	No, just grease and continue work						
500hrs Greasing - After the first 500hrs do the bushes then need greasing daily?	No, the bushes wont need greasing until the next 500hrs						
500hrs Greasing - Without daily greasing what cleans all the dirt out of the bush?	Machine is fitted with one way seals stopping dirt entering the bush but allowing old grease out when greasing						
How do I switch from ISO to SAE control patterns?	<p>The control pattern change-over switch is located under the operator station.</p> <ul style="list-style-type: none"> • Position 1 = SAE • Position 2 = ISO <p>Always refer to the in cab display for confirmation of control pattern selection.</p>						
How do I activate continuous auxiliary flow?	To activate constant flow, select right hand finger button on the right hand joystick. Please refer to page 15 for joystick control layout.						
What are the max flows and pressures of the Auxiliary circuits?	<table border="1" data-bbox="508 1074 1039 1217"> <thead> <tr> <th data-bbox="508 1074 680 1137"></th> <th data-bbox="680 1074 853 1137">Aux Flow (L/min)</th> <th data-bbox="853 1074 1039 1137">Aux Pressure bar (psi)</th> </tr> </thead> <tbody> <tr> <td data-bbox="508 1137 680 1217">19C-1e</td> <td data-bbox="680 1137 853 1217">32</td> <td data-bbox="853 1137 1039 1217">200 (2,898.5)</td> </tr> </tbody> </table>		Aux Flow (L/min)	Aux Pressure bar (psi)	19C-1e	32	200 (2,898.5)
	Aux Flow (L/min)	Aux Pressure bar (psi)					
19C-1e	32	200 (2,898.5)					



All rights reserved. No part of this publication may be reproduced, stored in a retrieval system, or transmitted in any form or by any other means, electronic, mechanical, photocopying or otherwise, without prior permission from JCB Sales. All references in this publication to operating weights, sizes, capacities and other performance measurements are provided for guidance only and may vary dependant upon the exact specification of the machine. They should not therefore be relied upon in relation to suitability for a particular application. Guidance and advice should always be sought from your JCB Dealer'. JCB reserves the right to change specifications without notice. Illustrations and specifications shown may include optional equipment and accessories.



JCB Sales Limited, Rokester, Staffordshire, United Kingdom ST14
5JP Tel: +44 1889 590312 Email: salesinfo@jcb.com

Download the very latest information on this product range at: www.jcb.com

The JCB logo is a registered trademark of J C Bamford Excavators Ltd. ©2009 JCB Sales.