

- Cutter is designed for use with the RIDGID 700 Power Drive. Use of other power drives may increase the risk of injury.
- Wear leather gloves when handling pipe. Burrs can penetrate cloth gloves.

SAVE THESE INSTRUCTIONS!

Description, Specifications and Standard Equipment

Description

The RIDGID 258 and 258XL Power Pipe Cutters are designed to squarely cut 2½" to 8" or 8" – 12" steel pipe. The cutting action is powered by the RIDGID 700 Power Drive in conjunction with a large diameter cutter wheel. The cutter wheel is advanced to the pipe via a pivot arm. The pivot arm advances the cutter wheel by utilizing a 10-ton hydraulic cylinder and foot pump.

The RIDGID 700 Portable Power Drive is an electro-motor-driven heavy-duty power drive which provides power for threading pipe, conduit and rod (bolt stock). In this case, the 700 Portable Power Drive is used as the power source to rotate the cutting blade.

Specifications

Description	258	258XL
Pipe Cutting Capacity.....	2½" – 8"	8" – 12"
Height (A)	22"	27"
Width (B)	11"	13"
Depth (C).....	19"	24"
Weight		
(without 700 PD)	95 lbs.	130 lbs.
(with 700 PD)	126 lbs.	161 lbs.

Standard Equipment

- 258 or 258XL Cutter Frame
- Two Speed Foot Pump with Hose and Coupling
- 774 Square Drive Adapter for 700 PD
- 258PS Ball Transfer Head Pipe Supports (2)
- E258 General Purpose Cutting Wheel (Schedule 40 – 80 Capacity)



Figure 1



Figure 1A

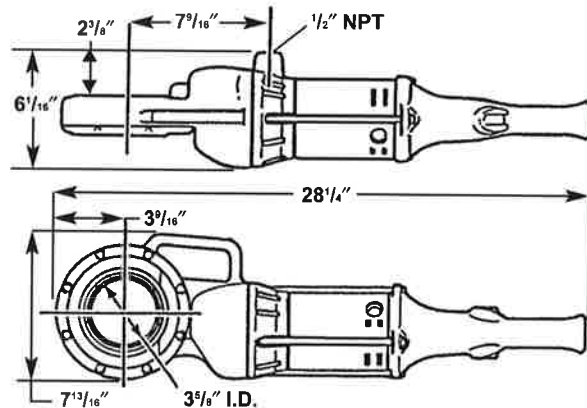

Figure 2 – No. 700 Power Drive Dimensions

Accessories

- 700 Power Drive (110 or 220 Volt)
- 258PS Ball Transfer Head Pipe Supports (2)
- Transport Cart for 258 and 258XL
- Cutter Wheel for Thin Wall Pipe (Schedule 10 – 20 capacity)
- Pipe Roller for Beveling