

CC6549DXLS Diesel Walk Behind Saw



Diesel

**Fast Cutting, Fuel Efficient and
Reliable 49 HP Diesel**

14" - 36" Blade Capacity

Self Propelled

Features & Benefits

- Blade shaft tachometer which gives true blade speed
- Quick release blade shaft/flange and rear wheels
- Less rear weight for easy maneuvering and reduced operator fatigue
- Strongest frame on the market
- Double concave roller bearings
- Fits through a 36" wide door frame (when guard is removed)



CC6549DXLS

Blade not included

Specifications

Maximum depth of cut with 14" blade:	4-1/2"
Maximum depth of cut with 20" blade:	7-1/2"
Maximum depth of cut with 26" blade:	10-1/2"
Maximum depth of cut with 30" blade:	11-3/4"
Maximum depth of cut with 36" blade:	14-3/4"
Maximum depth of cut with 42" blade:	17-1/4"
Blade shaft diameter:	1-3/4"
Arbor size:	1" with drive pin
Blade shaft drive:	10 belt
Blade mounting:	Right or Left
Blade raise & lower:	Electro-hydraulic pump
Transmission:	Eaton Model 10
Drive speed:	0-200 feet/min
Air filter:	4 stage
Fuel capacity	9 gallons

INCLUDES:

- | | |
|--------------------------------|---------------------------|
| Blade shaft tachometer | Slip-on blade guard |
| Hour meter | Cutting depth indicator |
| Frame lift | Telescoping front pointer |
| Quick disconnect blade flanges | |



Canadian Pricing



Sawing

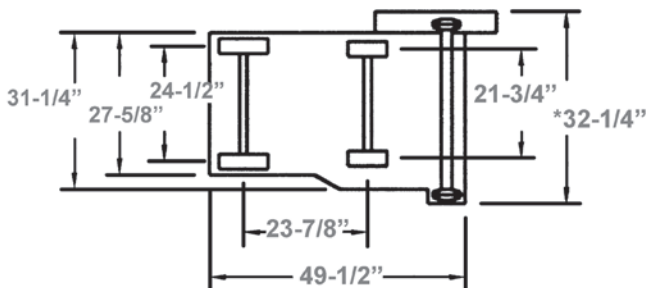
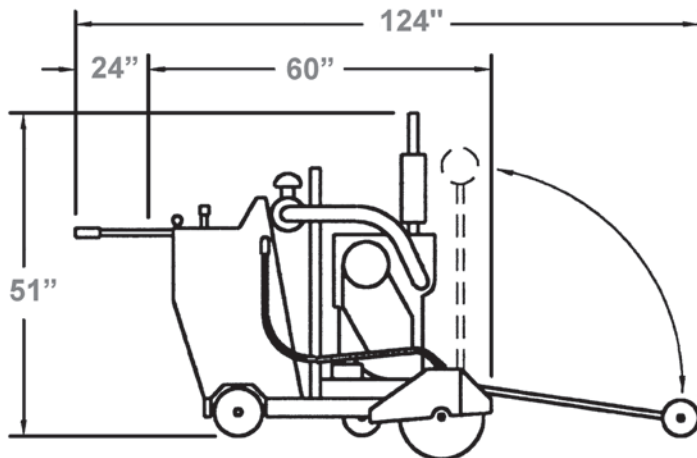

Horsepower and Torque as rated by the engine manufacturer.



Parts List # (Single Speed): 1801837
Parts List # (3-Speed): 1801874
Operator Manual #: 1801197