



To Whom It May Concern:

The Sherpa 100ECO, Battery Powered Skid Steer, weighs approximately 1600 pounds without the additional weight of an operator. The ground contact area of each of the four (4) wheels is approximately 25-30 square inches. Therefore, we have calculated tire contact ground pressure to be in the range of 13.3 – 16 psi without operator or additional attachments.

A handwritten signature in black ink that reads "Alex Berg". The signature is written in a cursive, flowing style.

Alex Berg
President
Triple E Equipment, Inc.



SHERPA 100 ECO

SHERPA 100 ECO Efficient and Environmentally Friendly

Hanenberg Materieel B.V. is the first manufacturer to introduce an electric mini skid-steer. The SHERPA 100 ECO is just as powerful as the model with the combustion engine and is particularly suitable for indoor demolition work and work in stables. The 76-cm wide mini skid-steer is powered by a surprisingly strong 2-HP front-mounted electric motor. Pressing the accelerator quickly builds up the pressure in the system. The space that normally contains the combustion engine now stores a 360-Ampere battery pack that powers the mini skid-steer for up to 7 hours.

The environmentally friendly and compact SHERPA 100 ECO can now do the physically demanding indoor work that you used to do manually. This nifty machine is extremely quiet and doesn't produce any unpleasant exhaust fumes.



Technical data SHERPA 100 ECO

Engine

Type: DC Motor (brushless)	
Capacity (kW/HP):	1,5/2
Revolutions per minute (rpm):	1800

Drive system

Hydraulic through 2 hydraulic wheel motors

Speed (steps, mph): 0-4

Capacity data

Breakout force (lbs):	1851
Tractive force (lbs):	1230
Hydraulic drive system (psi):	2756
Hydraulic tank capacity (gal):	11

Tipping load in straight position on LCD point ()

Pallet forks with weight low :	771
Pallet forks with weight high :	486
Bucket with weight low :	770
Bucket with weight high :	484

Tyres: 4.00x10

Brakes

Service brake: Hydrostatic on 2 rear wheels/
2 front wheels through chain transmission

Steering

Typ: Skid steering

Electrical system

Battery type: Traction battery	
Voltage (V):	24
Battery capacity (Ah):	360
Kerb weight (lbs):	1591

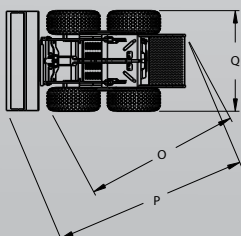
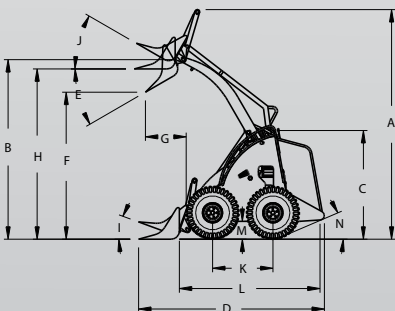

Dimensions

A Maximum height with bucket up	100 in	I Bucket angle when scooping low	26°
B Height hinge point coupling plate	81 in	J Bucket angle when scooping high	53°
C Maximum height with bucket low	47 in	K Wheelbase	26 in
D Length + bucket	85 in	L Length to coupling plate	60 in
E Bucket angle when dumping	51°	M Ground clearance	5 in
F Height underside of the bucket when dumping	58 in	N Rear Angle	14°
G Length from front wheel to bucket when dumping	8 in	O Turning radius	64 in
H Height bucket horizontally	73 in	P Turning radius with bucket	85 in
		Q Width	30 in