

Volvo Construction Equipment
Building Tomorrow



SD75B, SD115B

Volvo Single Drum Compactors 7-11.8 t / 15,430-26,000 lb 74-147 hp



A passion for performance

At Volvo Construction Equipment, we're not just coming along for the ride. Developing products and services that raise productivity – we are confident we can lower costs and increase profits for customers around the globe. Part of the Volvo Group, we are passionate about innovative solutions to help you work smarter – not harder.

Helping you to do more

Doing more with less is a trademark of Volvo Construction Equipment. High productivity has long been married to low energy consumption, ease of use and durability. When it comes to lowering life-cycle costs, Volvo is in a class of its own.

Designed to fit your needs

There is a lot riding on creating solutions that are suited to the particular needs of different industry applications. Innovation often involves high technology – but it doesn't always have to. Some of our best ideas have been simple, based on a clear and deep understanding of our customers' working lives.



You learn a lot in 180 years

Over the years, Volvo has advanced solutions that have revolutionized the use of construction equipment. No other name speaks Safety louder than Volvo. Protecting operators, those around them and minimizing our environmental impact are traditional values that continue to shape our product design philosophy.

We're on your side

We back the Volvo brand with the best people. Volvo is truly a global enterprise, one that is on standby to support customers quickly and efficiently – wherever they are.

We have a passion for performance.

A strong, dedicated, capable dealer network

Our dealers are strategically located throughout North America to provide the equipment you need and the parts and service support you demand for a productive and profitable operation.

The strength of our dealer network is enhanced with extensive individualized product support training at our best-in-class Customer Center in Shippensburg and through hands-on training. Using a great Product Demonstration Center featuring a dedicated area for most common applications, visitors operate equipment from our entire product line under a variety of simulated working conditions. This facility is in year-round use by our dealers and customers.

Building the best starts right here.

The products designed and manufactured by Volvo Construction Equipment have their beginnings at the most advanced Research & Design centers in the industry. Volvo CE machines are designed in 11 R&D centers and produced in 15 manufacturing facilities across the world.

The major R&D center and manufacturing plant in the Americas is located in Shippensburg, Pennsylvania. This facility has been in operation for over 30 years and – with its recently added 200,000 sq. ft. expansion – now covers 570,000 sq. ft. on an 80 acre campus. Dedicated work teams and highly advanced technologies and techniques using the Volvo Production System ensure continuous quality improvements, labor savings and cost control to reach the high quality that our customers have come to expect from Volvo.



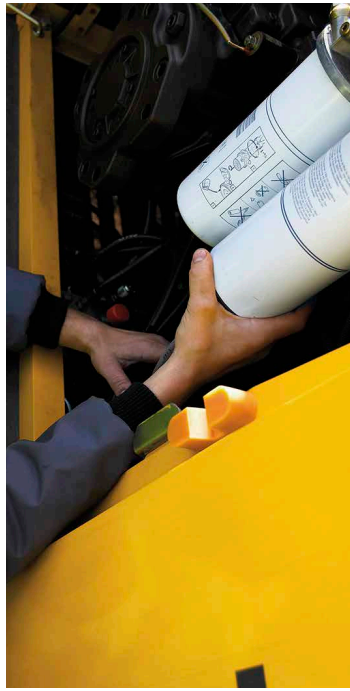

Volvo Trucks



Renault Trucks



Mack Trucks



UD Trucks



Volvo Buses



Volvo Construction Equipment



Volvo Penta



Volvo Financial Services

Versatile performance

The new Volvo SD75B and SD115B soil compactors are packed with advanced technology. The drum is configured with ease while the engine controls itself. The compactors adapt to your application and jobsite to provide maximum versatility and performance.

Frequency and amplitude choices

Easily adjust the vibration frequency from the operator console to compensate for changing soil types and conditions. Two frequency settings are standard and for even greater versatility, five frequency options are available. High and low amplitudes can also be selected.

Adaptive power

Adaptive power tailors machine performance by adjusting engine and hydraulic systems to individual job site requirements, providing the exact amount of power needed for increased efficiency. It's designed to run the machine at the optimal level needed for the job.



Application versatility

The machine can be set up in three different configurations and is available with smooth or padfoot drum. The compactor is quickly and easily converted from a smooth drum by clamping on a padfoot shell. The padfoot shell kit allows the machine to work in different applications and increases versatility.

Gradeability

The Volvo traction system provides excellent climbing and traction capabilities in difficult applications, such as steep inclines or slippery surfaces. The system prevents wheel or drum spin, improving gradeability, performance and productivity. For the most demanding applications, the High Traction variant is also available, delivering additional torque to easily climb extreme slopes.





DRUM PERFORMANCE

Volvo's advanced drum control system delivers multiple frequency, dual amplitude, and optimized centrifugal force – matching the drum's performance to your application. The choice of high or low amplitude is easily selected, giving you the flexibility to adjust the drum's dynamic force based on the job and material depth. The auto vibration feature also increases ease of operation and productivity.



VOLVO ENGINE

Volvo's premium Tier 4 Final engine delivers high torque at low rpm for superior performance and low fuel consumption. Designed to lower emissions and increase efficiency without compromising power.

Power up, fuel down

The perfectly optimised Volvo Tier 4 Final engine delivers high torque at low rpm for superior performance and low fuel consumption. The compactor's engine has been developed to offer greater fuel efficiency, increasing uptime and reducing costs.

Efficient cooling system

The hydraulically-driven fan with variable speed draws power only when needed. Lower fan speeds reduce noise, resulting in greater operator comfort and a lower total cost of ownership.



ECO mode

ECO mode is now standard and is always turned on by default. It adjusts the engine speed to match the operation mode and up to a 40% reduction in fuel consumption is achieved with ECO mode.

**Not applicable to SD75B*

Passive regeneration

The new passive regeneration provides continuous and simplified operation. Volvo's passive regeneration cleans the filters automatically during normal operation without any input from the operator or effect on performance.



Eccentric design

The eccentric design delivers more efficiency while using less power. Matching the required performance to suit your application, the eccentric is designed for faster ramp up speeds at lower pressure for increased fuel efficiency.

Packed with intelligence

COMPACT ASSIST

The Compact Assist option improves compaction efficiency by preventing unnecessary passes and identifying areas that might not have achieved ideal compaction.

ECO mode

ECO mode can be selected by the operator. This feature adjusts the engine speed to match the operation mode.

HIGH QUALITY COMPONENTS

The compactor features the highest quality components, clever routing and clean design.

Heavy-duty

The heavy-duty drum, center joint and front frame components are designed and manufactured with durability in mind.

Operator Environment

The ROPS/FOPS certified cab or open operator's area provides a safe and comfortable working environment with all-around visibility.

DRUM PERFORMANCE

Volvo's advanced drum control system delivers multiple frequencies, dual amplitude, and optimized centrifugal force.





VOLVO ENGINE

The perfectly optimised Volvo Tier 4F engine delivers high torque at low rpm for superior performance and low fuel consumption.

Passive regeneration

Passive regeneration functions automatically during operation without input from the operator or effect on machine performance.

Service Access

The electric engine hood lifts up giving extensive ground level access to the engine compartment.

ActiveCare Direct

Maximize machine uptime and reduce repair costs with ActiveCare Direct, with 24-7/365 machine monitoring as well as customer reports.

Impact meter

Integrated into the display, the impact meter ensures you travel at the right speed for target compaction.

Gradeability

The Volvo traction system provides excellent climbing and traction capabilities in difficult applications. For the most demanding applications, the High Traction variant is also available.

Control in comfort

Step up to the Volvo designed cab and experience industry-leading low noise levels, ultimate comfort and a productive working environment. Safe, spacious and with improved all-around visibility, operators will work efficiently with less fatigue in a Volvo compactor.

Operator Environment

The ROPS/FOPS certified cab provides a safe and comfortable working environment with an efficient heating and air conditioning system and all-around visibility. With floor to ceiling cab glass, the operator has an excellent forward drum view as well as superior front and rear visibility.

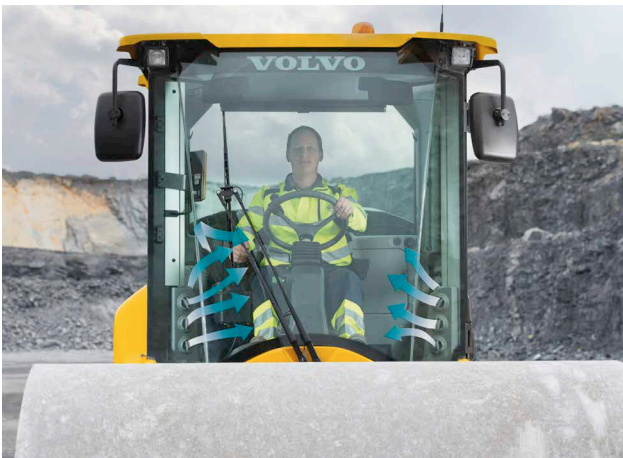

HVAC system

The cab is equipped with industry-leading climate control to ensure a comfortable environment inside the cab, whether heating or air conditioning is required. High air intake and positive cabin pressure helps to reduce dust from entering the cab.

Operator display

The new high-tech color operator display presents operational information and key diagnostics, reducing the need for regular physical checks. Easy to see in direct sunlight, further functions include service interval information and machine operating conditions. The control keypad is conveniently located on the operator's side console and controls are grouped together for comfort and efficiency.



Impact meter and compaction gauge

Integrated into the display, the impact meter provides the operator with the impacts per meter, helping ensure they travel at the optimal speed for both target compaction and a uniform, smooth finish. The compaction gauge displays the CMV, an estimated value of soil stiffness, which helps to indicate when compaction has been achieved.



COMPACT ASSIST

Compact Assist for soil can display both pass mapping or CMV (compaction measurement value), an estimated value for soil stiffness. This option can improve compaction efficiency by preventing unnecessary passes and identifying areas that might not have achieved ideal compaction.



HIGH QUALITY COMPONENTS

The compactor features the highest quality components, clever routing and clean design. The engine, hydraulics and electronic components work in harmony to deliver superior performance and increase machine life.

Robust and reliable

Volvo Construction Equipment produces the most robust and durable compactors on the market. The SD75B and SD115B machines provide easy service access for increased uptime and quick maintenance.

Service Access

The cab tilt is standard, providing access to all hydraulic components. For class-leading access, the electric engine hood lifts up giving extensive ground level access to the engine compartment. Maintenance and inspections can be conducted more efficiently with minimal downtime – increasing overall productivity and reliability.



Sealed electronics

All components and electronics have been moved into the cab and mounted on the rear wall, protecting them from the elements. Fuses are accessible behind the fuse panel for improved accessibility.

ActiveCare Direct

Maximize machine uptime and reduce repair costs with ActiveCare Direct. ActiveCare Direct is a predictive and preventive maintenance service that provides 24-7/365 machine monitoring as well as customer reports.



Heavy-duty

The heavy-duty drum, centre joint and front frame components are designed and manufactured with durability in mind. The thick steel drum shell is engineered for longevity and performance. Frames are robotically welded and built from high quality steel with precise and consistent welds guaranteeing a strong structure.

Specifications

Model			SD75B				SD115B				
Drum type			Smooth		Padfoot		Smooth		Padfoot		
Machine Weights (inc. ROPS & inside scraper)											
Operating Weight (CECE)	kg	lb	7,192	15,850	7,368	16,245	11,643	25,615	11,800	25,960	
Static Weight @ Drum	kg	lb	3,610	8,025	3,786	8,350	6,243	13,735	6,400	14,080	
Static Weight @ Tyres	kg	lb	3,582	7,900	3,582	7,900	5,400	11,880	5,400	11,880	
Shipping Weight	kg	lb	7,081	15,610	7,257	1,600	11,513	25,329	11,670	25,674	
Drum											
Width	mm	in	1,676	66	1,676	66	2,134	84	2,134	84	
Diameter	mm	in	1,215	48	1,207	48	1,500	59	1,295	51	
Shell Thickness	mm	in	20	1	16	1	25	1	25	1	
Diameter Over Pad Feet	mm	in	-	-	1,354	54	-	-	1,549	61	
Pad Feet	number of		-	-	84		-	-		112	
Pad Height	mm	in	-	-	75	3	-	-	127	5	
Pad Tip Area	cm ²	in ²	-	-	125	19	-	-	135.3	21	
Vibration											
Frequency	Hz	vpm	30.8/33.8	1,850/2,025	30.8/33.8	1,850/2,025	30.8/33.8	1,850/2,025	30.8/33.8	1,850/2,025	
Optional 5 Frequency	High Amp	Hz	vpm	23.3-30.8	1,398-1,850	23.3-30.8	1,398-1,850	23.3-30.8	1,398-1,850	23.3-30.8	
Centrifugal Force	High Amp	kN	lb	139	31,250	139	31,250	258	58,050	258	
	Low Amp	kN	lb	121	27,200	121	27,200	242	54,400	242	
Nominal Amplitude	High Amp	mm	in	1.94	0.08	1.71	0.06	1.92	0.08	1.82	
	Low Amp	mm	in	1.41	0.06	1.25	0.05	1.5	0.06	1.42	
Propulsion											
Type	Hydrostatic										
Tyre	14.9-24 R3 6PR TT				14.9-24 R1 6PR TL		23.1-26 R3 8PR TT		23.1-26 R1 8PR TL		
Drum Drive	LSHT Motor					Planetary Gear Box					
Travel Speed											
High	km/h	mph	12.3	7.6	13	8.1	10	6.2	10	6.2	
Low	km/h	mph	6.5	4.0	7.5	4.7	4.5	2.8	4.3	2.7	
Engine											
Make / Model	Volvo D3.8 Tier 4 F					Volvo D4 Tier 4 F					
Engine Type	Turbocharged 4 cylinder					Turbocharged 4-cylinder					
Rated Power @ 2 200 rpm	kW	hp	55.4		74		110		147		
Electrical System											
Voltage (Negative ground)	Volt	12					24				
Alternator	Ah	100					80				
Batteries	CCA	1 x 1,000					2 x 1,000				
Brakes											
Service	Hydrostatic										
Parking / Secondary	Spring-applied, hydraulically released on drum & axle										
Miscellaneous											
Articulation Angle	°	+/- 38					+/- 35				
Oscillation Angle	°	+/- 12					+/- 12				
Inside turning radius	mm	in	3,249	128	3,249	128	3,800	149.6	3,800	149.6	
DEF Tank Capacity	l	gal	20		5		20		5		
Fuel Capacity	l	gal	115		30		165		43.5		
Hydraulic Oil Capacity	l	gal	60		16		75		20		
Guaranteed Sound Level											
Operator's Ear, acc. to ISO 11203:2009	LpA dB(A)	74 (Cab) - 87 (Canopy)					75 (Cab) - 87 (Canopy)				
External, acc. to Directive 2000/14/EC	LwA dB(A)	104					105				

GRADEABILITY

Model			SD75B				SD115B			
Drum type			Smooth		Padfoot		Smooth		Padfoot	
No traction enhancement			Moderate							
With flow divider option			High							
With High Traction variant (includes flow divider and high torque axle options)			-				Extreme			

Moderate applications include highway construction, finish grades, and slopes up to 30%.

High applications include trenching, infrastructure projects, and slopes ranging from 25% to 40%.

Extreme applications include thick lifts of loose material, use of leveling blades, and slopes over 30% such as landfills.

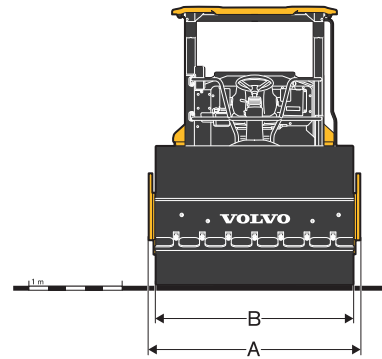
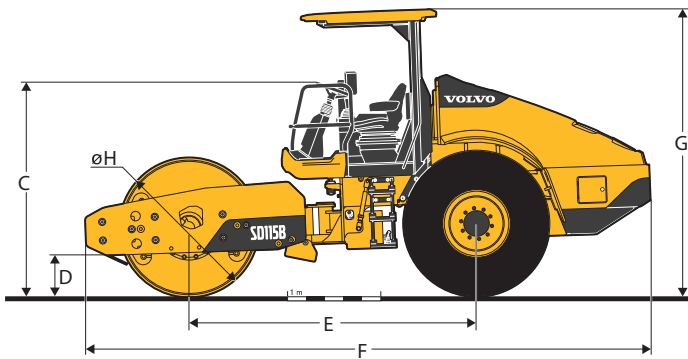

DIMENSIONS

Model	SD75B				SD115B			
	Smooth drum		Padfoot drum		Smooth drum		Padfoot drum	
	mm	in	mm	in	mm	in	mm	in
A	1,830	72	1,830	72	2,286	90	2,286	90
B	1,676	66	1,676	66	2,134	84	2,134	84
C	2,183	86	2,252	88.7	2,269	89.3	2,288	90.1
D	383	15.1	452	17.8	483	19	498	19.6
E	2,677	105.4	2,677	105.4	3,095	121.9	3,095	121.9
F	5,044	198.6	5,044	198.6	6,091	239.8	6,091	239.8
G	2,924	115.1	2,993	117.8	3,000	118.1	3,020	118.9
H	1,215	47.8	1,354	53.3	1,500	59.1	1,549	61

Equipments

SELECTION OF VOLVO OPTIONAL EQUIPMENT

Tires



Padfoot drum



Blade



Work lights

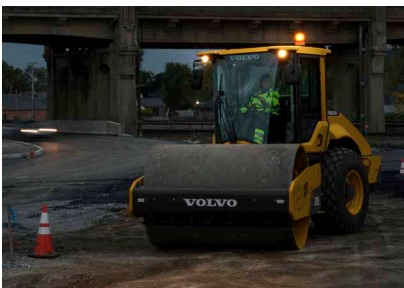

Compact Assist

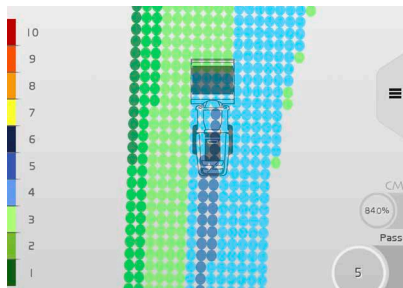

High Traction Variant



Not all products are available in all markets. Under our policy of continuous improvement, we reserve the right to change specifications and design without prior notice. The illustrations do not necessarily show the standard version of the machine.

VOLVO

Volvo Construction Equipment

volvoce.com