

ENGINE

Make	Cummins Tier 3 Certified
Type	QSB 4.5
Gross horsepower	148 hp (110 kW)

ELECTRICAL

Voltage	24 Volts
Batteries	2 x 100 amp
Alternator	45 amp

STEERING

Pump (gear type)	1
Cylinders	2
Angle (left & right)	36°
Oscillation angle	10°
Inside turning radius	10.0 ft (3.05 m)
Outside turning radius	17.6 ft (5.37 m)

WEIGHT - SMOOTH DRUM

Operating weight without cab	25,530 lbs (11 580 kg)
Max. weight with cab	25,710 lbs (11 660 kg)
Drum weight	16,212 lbs (7354 kg)
Static linear load	182 lb/in (32.4 kg/cm)
Tire ballast	2,646 lbs (1200 kg)

WEIGHT - PADFOOT DRUM

Operating weight without cab	26,870 lbs (12 188 kg)
Max weight with cab	27,050 lbs (12 270 kg)
Tire ballast	2,646 lbs (1200 kg)

TRAVEL

Hydraulic circuit type	Closed
Variable displacement axial piston type wheel drive pump	1
Hydraulic fixed displacement wheel drive motors	2
Drive motor interlock	Yes
Hydraulic variable displacement drum drive motor	1
F/R travel speed range	4
Working speeds	mph (km/h)
1st (max)	1.5 (2.5)
2nd (max)	2.17 (3.5)
3rd (max)	3.4 (5.5)
Max travel speed	6.9 (11.1)
Gradeability (without traction assist)	45%
Transversal stability (machine in straight line)	36° slope

VIBRATION

Hydraulic circuit type	Closed
Variable displacement axial piston type pump	1
Fixed displacement hydraulic motor	1
Vibration modes	2
Vibration	2 eccentric weights circular pattern / continuously adjustable
Frequency	
Low	1920 VPM (32 Hz)
High	2100 VPM (35 Hz)
Amplitude	
Low	.045 in (1.15 mm)
High	.073 in (1.85 mm)
Centrifugal force	
Low	46,310 lbs (206 kN)
High	62,250 lbs (277 kN)

TIRES

Size	23.1 x 26 10PR
Smooth drum	Diamond or traction tread
Padfoot drum	Traction tread
Tire ballast	Traction tread only

CAPACITIES

Fuel tank	108 gal (410 L)
Engine oil	17.2 qt (16.3 L)
Engine coolant	26.4 qt (25 L)
Hydraulic reservoir	95 qt (90 L)
Transmission	4.4 qt (4.2 L)
Drive axle	2.9 qt (2.8 L)
Vibration system	8.4 qt (8 L)

OPERATOR STATION

Isolated from chassis by flexible shock absorbers, handrail, dual rearview mirrors, front lighting, instrument panel anti-vandal guard. Vinyl suspension seat with armrests and 2 inch (51 mm) retractable seat belt. Exceptional front/rear visibility.

STANDARD EQUIPMENT

- ROPS & FOPS protection
- Hydrostatic drive for both drum and wheels
- Dual amplitude vibration
- Interwheel differential lock
- Articulated chassis
- Front and rear pull points
- 4 point lift and tie down provision
- Fan guard
- Backup alarm
- Halogen work lights, 2F/2R
- Auto-vibration control
- Master disconnect switch
- Spring applied, hydraulic release parking brake
- 3 working speeds / 1 transport speed
- Single lever speed / direction control
- Steering wheel spinner knob
- Lockable tool box
- Cup holder
- Horn
- Emergency stop button
- Spin-on fuel, engine oil and hydraulic filters
- LCD monitor

OPTIONAL EQUIPMENT

Traction Assist Systems

- ASC-anti-slip control (smooth drum option only)
- HD-heavy duty (includes ASC; smooth drum or padfoot drum)
- HT-high traction (includes ASC; padfoot drum with leveling blade only)

Padfoot shell kit with scrapers

Pressurized cab with heat and ventilation

- Air conditioning
- Radio ready (antenna and 2 speakers / no radio)

Engine filter pre-cleaner

Electric engine hood tilt

3 in (76.2 mm) retractable seat belt

Compaction meter system (Voelkel)

Compaction meter printer

Side slope rollover warning system

Rotating beacon

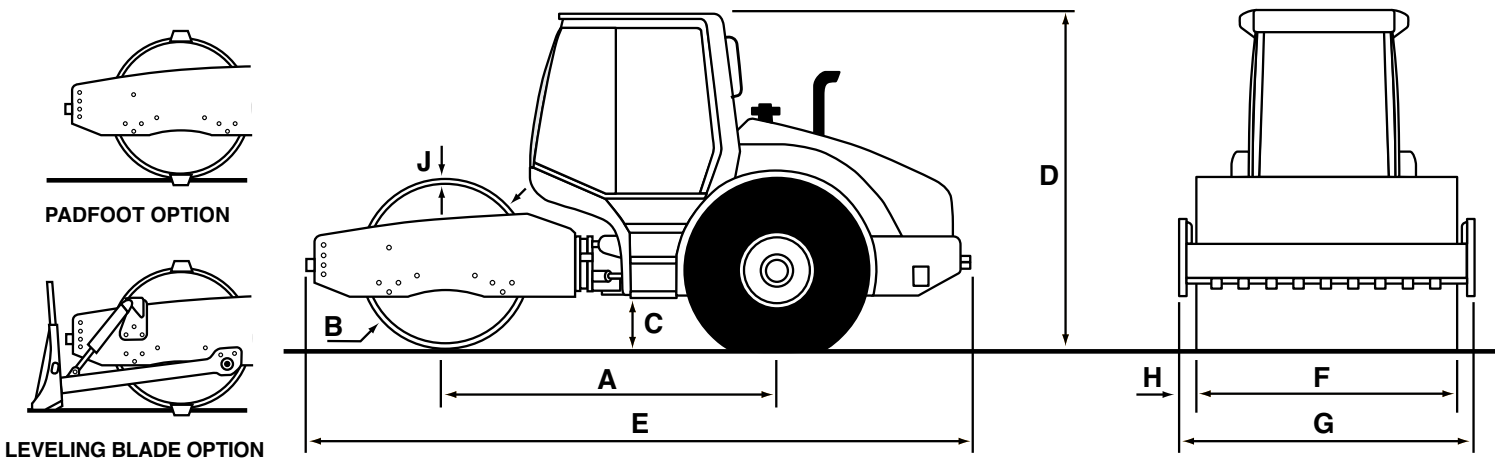

DIMENSIONS

A. Wheelbase	113 in (2.9 m)
B. Drum diameter	
Smooth drum	59 in (1.5 m)
Padfoot drum	64.6 in (1.64 m)
C. Ground clearance	17.3 in (0.44 m)
D. Overall height	121 in (3.07 m)
E. Overall length	227 in (5.8 m)
F. Drum width	84 in (2.13 m)
G. Overall width	88.9 in (2.25 m)
H. Frame extensions	4 in (0.11 m)
J. Drum thickness	1.0 in (0.025 m)



NOTE: All specifications are stated in accordance with SAE Standards or Recommended Practices, where applicable.

NOTE: All engines meet current EPA emissions requirements.

IMPORTANT: Case Construction Equipment Inc. reserves the right to change these specifications without notice and without incurring any obligation relating to such change. Case Construction Equipment Inc. does not warrant the safety or reliability of attachments from other manufacturers.

Case is a registered trademark of CNH America LLC. Any trademarks referred to herein, in association with goods and/or services of companies other than CNH America LLC, are the property of those respective companies.



www.casece.com

