

NEW



SINGLE DRUM SOIL COMPACTOR | VM117/VM137

Operating weight (cabin): 24,912lbs/27,668lbs Engine power: 125-145hp (93-108kW) Drum width: 83in



PRODUCTIVITY MAXIMIZED.

THE VMI17 AND VMI37 ARE DESIGNED TO GIVE YOU ULTIMATE PRODUCTIVITY. EQUIPPED WITH INNOVATIVE ECOMAX ENGINES THEY PROVIDE REDUCED LIFE CYCLE COSTS AND FUEL CONSUMPTION WITHOUT THE NEED FOR A DPF.



You can expect class-leading low fuel consumption from a JCB Stage 3B/T4i EcoMAX engine. This is partly thanks to a variable geometry turbo, which helps to provide improved cycle times and tractive effort at low engine speeds.

Built for efficiency.

1 The Stage 3B/T4i-compliant JCB EcoMAX engine is equipped with a variable fan as standard, providing your VMI17 or VMI37 with fuel savings of up to 6%.

2 The JCB EcoMAX engine delivers a massive 405.7 lbf ft (VMI17) and 413 lbf ft (VMI37) of torque, at low engine speeds for optimum responsiveness, for fuel-efficient matching of transmission and hydraulics.



1



2

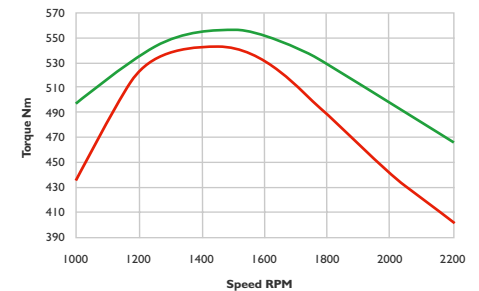

Saving time and money.

3 Both of these models boast quick (up to 7 mph) travel times around site, which also speeds up preparation for the next compaction pass.

4 These soil compactors have a tight turning circle for excellent maneuverability on confined sites.

Complete compaction.

5 Front weight ratio is high which provides a very high static linear load. Combined with optimized amplitude and frequency, this helps you to achieve the ultimate homogenous compaction performance in the lowest possible number of passes on every surface from sand to rock.

You'll benefit from class-leading 60% gradeability with an EcoMAX engine, thus ensuring great versatility and productivity anywhere in the world. The motor itself is a high performance unit (VM117 – 1.16 gal, VM137 – 1.27 gal), and it's combined with high-torque hydraulic components and optimized weight distribution.

6 If you plan to use your machine to compact clay, opt for our pad foot drum to improve water evaporation and, therefore, create more stable soil.

For added versatility, choose a pad foot shell kit, which offers the best of both worlds.



MAXIMUM COMPACTED LAYER THICKNESS					
Model		Rock	Sand/Gravel	Mixed Soil	Clay/Loam
VM117 D	in	0.02	0.01-0.02	0.01-0.02	0.01
VM117 PD	in	–	–	–	0.01
VM137 D	in	0.03-0.04	0.02-0.02	0.02	0.01
VM137 PD	in	–	–	–	0.02

QUALITY, RELIABILITY AND DURABILITY.

SOIL COMPACTORS HAVE TOUGH LIVES, WHICH IS WHY WE'VE DESIGNED AND BUILT THE VMI17 AND VMI37 TO BE AS ROBUST AS THEY CAN BE. PRODUCTIVITY AND UPTIME ARE MAXIMIZED ACCORDINGLY.



1

Quality at its best.

1 For maximum reliability, our new exciter system only has 2 moving parts, providing standard dual amplitude / dual frequency setting.



2

2 The fuse box is positioned underneath the seat console, well protected and within easy reach.

3 All of our soil compactors are subjected to a 2-hour hot test to make sure they're ready for trouble-free use from day one.

4 We use advanced manufacturing and assembly processes to ensure maximum precision and quality of components.



3



4

Designed for reliability.

5 The robust maintenance-free center joint has been the trusted mainstay of JCB's VM115 soil roller generation and it continues to offer reduced servicing costs on these machines too.

6 To prove our EcoMAX engines' durability, we've done 110,000 hours of testing in 70 different machines across the toughest applications and environments.

7 The frame of the VM117 and VM137 is designed using finite element analysis, and it's fully strain gauged. It's also been tried and tested across various machines, applications and environments.

8 A sturdy rear frame structure protects the glass fiber engine hood and the cleverly integrated rear light cluster*.

*Rear road lights are optional.

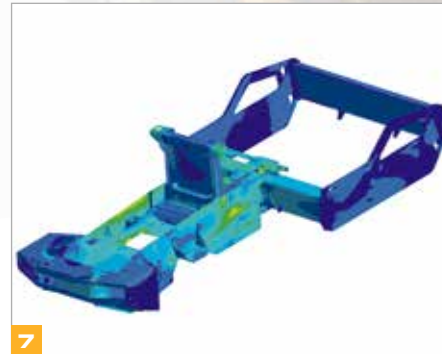

VISIBLE BENEFITS.

WE BELIEVE THAT IN ORDER FOR SOIL COMPACTORS TO OFFER MAXIMUM PRODUCTIVITY, THEY NEED TO FIRST OFFER MAXIMUM VISIBILITY. THE VMI17 AND VMI37 ARE DESIGNED TO DO JUST THAT.

360° visibility.

- 1 There's superb all-round visibility on a VMI17 and VMI37 courtesy of a pillarless front cab design, and a sloping rear hood.
- 2 We use flat glass panels on these soil compactors (unlike our competitors), which makes replacement quick and easy.
- 3 Precision is guaranteed with the new clear view front screen and minimal front display, which help to provide an unrestricted view to the front drum edges.
- 4 The design of these machines incorporates an angled hood profile for an unrestricted view of the rear edge.



To improve safety and precision during operation, there's a low rear hood profile and no exhaust pipe in the field of vision, which makes for an unrestricted view to the rear and corners.



COMFORTABLY SUPERIOR.

TO GET THE MOST OUT OF YOUR VMI17 AND VMI37, IT'S CRUCIAL THAT OPERATORS CAN PERFORM THEIR JOB EFFICIENTLY AND IN ALL-DAY COMFORT. AS SUCH, BOTH MACHINES ARE DESIGNED TO OFFER A GREAT WORKING ENVIRONMENT.

Designed for ease of use.

6 Operators can get working quickly on a VMI17 or VMI37 because of the intuitive, easy-to-use and ergonomic controls, all laid out in the industry standard.

6 Our easily adjustable tilting steering column provides maximum comfort.

7 When operators are getting in and out, there are three points of contact at all times; access steps are inclined and equally spaced, and there are well-positioned grab handles.

To make life easier, you only need one key to operate the ignition, door and hood.



JCB's standard-fit automatic vibration control (AVC) activates whenever the drive lever is moved from the neutral position, increasing comfort and making compaction as consistent as possible.

There's a large range of seat options, including mechanical or air suspension and vinyl or fabric bases. No matter which you choose, you'll get a high back, an armrest, a document pouch and full adjustment, along with an optional pivoting function.

Comfort on the move.

8 Fatigue-free all-day operation comes as standard: these machines are designed to offer low in-cab noise levels. What's more, by isolating the operator stand with 4 heavy duty rubber mounts, we've ensured class-leading low vibration levels too.

8 The well positioned colored TFT display provides the operator with direct reading machine data and error information.



LESS SERVICING, MORE SERVICE.

WE UNDERSTAND THAT A SOIL COMPACTOR IS ONLY PROVIDING ULTIMATE PRODUCTIVITY AS LONG AS IT'S ON-SITE WORKING FOR YOU. THAT'S WHY WE'VE DESIGNED THE VMI17 AND VMI37 TO OFFER MAXIMUM UPTIME WITH SIMPLE, MINIMIZED SERVICING.

Routine maintenance.

1 For ease of servicing, the VMI17 and VMI37 are designed so that all daily checks can be done from ground level on one side. A wide opening rear hood gives fast access to the engine compartment.

2 Testing and servicing are quick and easy because service ports, key fuses and the isolator key are all centralized and easy to access. An emergency towing valve is standard-fit on both machines.

3 To extend service intervals (and therefore productivity) both models feature a cyclonic air cleaner which reduces debris build-up in the air filter. An air intake scavenge system then removes the debris.

4 Local JCB dealer servicing is easy and cost-effective, with all aftermarket requirements catered for.



The cooling pack is easy to get into and clean, which optimizes engine cooling. The fuel tank is located behind simple panels for similarly straightforward access, allowing ground-level filling and cleaning.



Drum maintenance.

- 5 The front frame is fully bolted for great service access to the drum. The bolt heads are fully inserted into a rigid side frame.
- 6 A long service life and reduced running costs are ensured by JCB's unique preloaded rubber mountings; the design means that the rubber mounts can't be overloaded and can be quickly replaced.
- 7 The hydraulic hoses are completely protected from potential damage and dirt by a massive cover plate.



COMPACTION MEASUREMENT.

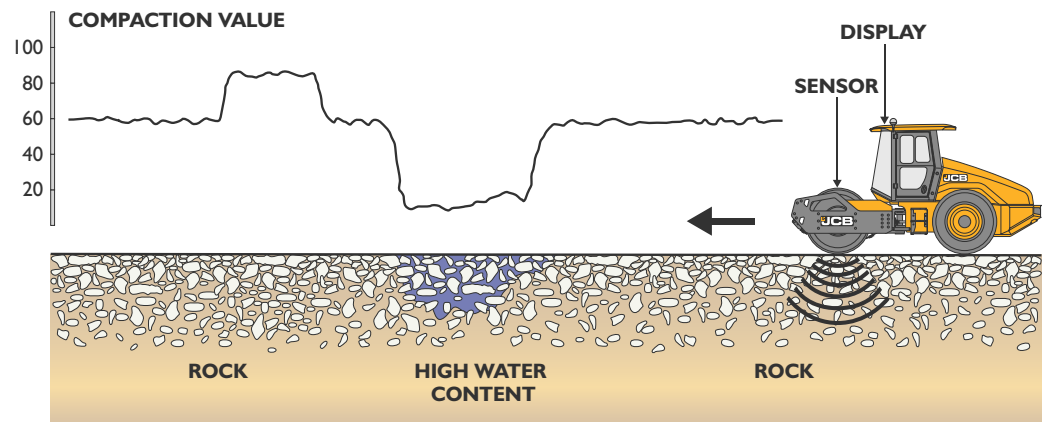

THE INNOVATIVE TECHNOLOGIES USED ON THE VMI17 AND VMI37 ARE INTUITIVE AND RELIABLE UNDER ALL WORKING CONDITIONS, ENSURING THAT YOUR COMPACTION WORK IS AS EFFICIENT, SAFE AND SUCCESSFUL AS CAN BE.



Efficient compaction.

To make your compaction operation as efficient as possible, you can fit optional JCB COMPATRONIC systems to your VMI17 and VMI37. There are three systems available, ranging from basic to high-end; whichever one you opt for, an accelerator sensor mounted next to the drum will measure the reaction from the ground and provide feedback about the rebound to the corresponding system.

The upshot is that you can minimize your number of passes, avoid over-compaction and prevent jump operation, which can damage both machinery and soil composition. The more sophisticated COMPATRONIC PRO and NAV versions are comprehensive compaction measurement systems with tracking and documentation functions for quality control.

COMPATRONIC	COMPATRONIC PRO	COMPATRONIC NAV
		
<p>Round display with LED scale for display of the relative compaction value, warning lamp for jump operation and LED display for vibratory frequency</p>	<p>Economic solution for a comprehensive compaction control system with a TCD display for a track view up to 18 tracks. Display of the relative compaction value, working speed, amplitude and frequency as well as jump operation.</p>	<p>High end comprehensive compaction control system with a colored tablet and easy to run operator menu. Three working modes to achieve required compaction specification are possible (number of passes, relative compaction value in relation to plan value and increase of compaction per pass).</p>
<p>Search for weak compaction areas</p>	<p>Print functionality</p>	<p>Exchange of job data between office desktop and tablet is possible via mobile (GPRS) or USB.</p>
<p>Reduce number of passes & avoid overcompaction</p>	<p>GPS sensor optional</p>	<p>GPS sensor allows true positioning of the machine in construction drawing, visible on tablet screen.</p>



LIVELINK, WORK SMARTER.

LIVELINK IS AN INNOVATIVE SOFTWARE SYSTEM THAT LETS YOU MANAGE JCB MACHINES REMOTELY – ONLINE, BY EMAIL OR BY MOBILE PHONE. ACCESS EVERYTHING FROM MACHINE ALERTS TO FUEL REPORTS AND HISTORY INFORMATION, WITH ALL DATA STORED AT A SECURE CENTER.

Productivity and cost benefits

By providing information like idle time monitoring and machine fuel consumption, JCB Livelink helps reduce your fuel usage, saving money and improving productivity. Machine location information can help improve efficiency and perhaps even reduce insurance costs.

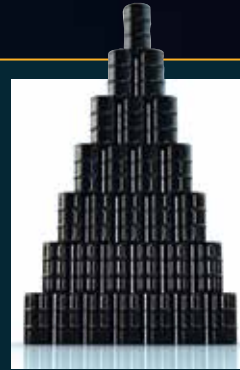

Maintenance benefits

Manage machine maintenance easily – accurate hours monitoring and service alerts improve maintenance planning, while real-time location data helps you manage your fleet. Critical machine alerts and maintenance history records are also available.



Security benefits

Livelink's real-time geofencing alerts tell you when machines move out of predetermined zones, and real-time curfew alerts inform you of unauthorized usage. Further benefits include real-time location information.



VALUE ADDED.

JCB'S WORLDWIDE CUSTOMER SUPPORT IS FIRST CLASS. WHATEVER YOU NEED AND WHEREVER YOU ARE, WE'LL BE AVAILABLE QUICKLY AND EFFICIENTLY TO HELP MAKE SURE YOUR MACHINERY IS PERFORMING TO ITS FULL POTENTIAL.



1 Our Technical Support Service provides instant access to factory expertise, day or night, while our Finance and Insurance teams are always on hand to provide fast, flexible, competitive quotes.

2 The global network of JCB Parts Centers is another model of efficiency; with 16 regional bases, we can deliver around 95% of all parts anywhere in the world within 24 hours. Our genuine JCB parts are designed to work in perfect harmony with your machine for optimum performance and productivity.



3 JCB Assetcare offers comprehensive extended warranties and service agreements, as well as service-only or repair and maintenance contracts. Irrespective of what you opt for, our Maintenance teams around the world charge competitive labor rates, and offer non-obligation quotations as well as fast, efficient insurance repair work.

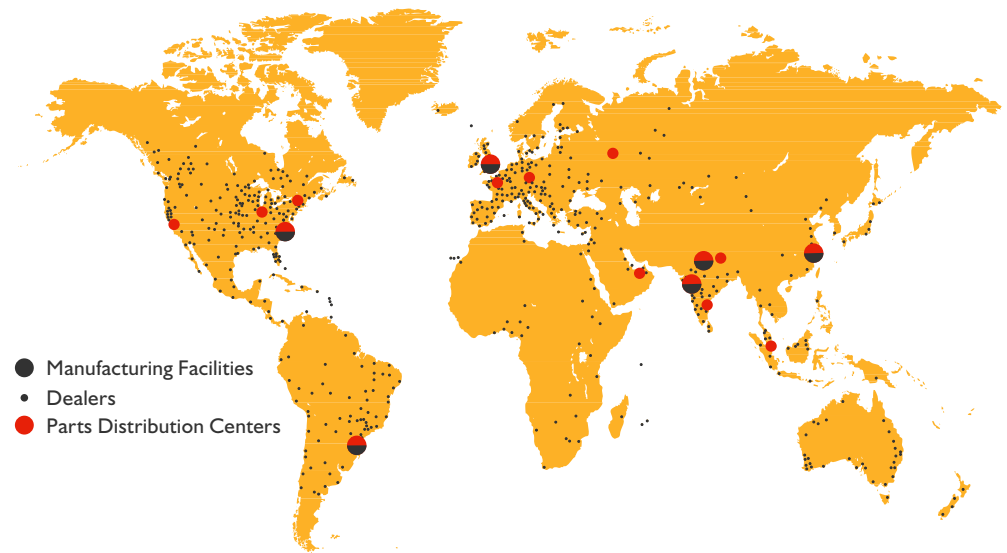

OPTIONS LIST.

WHICHEVER OPTION YOU CHOOSE - FULLY GLAZED CAB OR ROPS STRUCTURE WITH SUNROOF - OPERATOR COMFORT AND SAFETY ARE SUPERB, HELPING YOU MAKE COMPACTION WORK MORE PROFITABLE.

VMI17 AND VMI37

STANDARD FEATURES

Hydrostatic rear axle and drum drive
Hydrostatic vibration drive
Servo assisted center articulation with vertical oscillation
JCB axle with limited slip differential
Info and warning display
One lever control for propulsion and vibration
AVC (Automatic Vibration Control)
Uphill / down hill traction control
Power charger 12V
Fully adjustable operator seat
Adjustable steering column

Front and rear steel scrapers
Centralized hydraulic service station
Battery main switch
Hydraulic hand pump for brake release
3 stage air cleaner
Air intake scavenge system
One key solution
Vibration isolated operator stand
Noise isolation
Emergency Stop switch
Back-up warning horn
Live Link.

OPTIONS

Cabin
Heating
Air Conditioning
Radio
ROPS/FOPS incl. handrails
Sunroof
Instrument panel cover
Halogen working lights
LED working lights
Road traffic lights
Rotary Beacon

Immobilizer
Polyurethane scrapers (only D)
PD shell kit (only D)
Leveling blade
Seat variants Vinyl or fabric seat, fixed or pivoting seat console, mechanical or air suspension
3" seat belt
Compatronic (compaction measurement systems)
Grid heater
Fuel lubrication filter
Bio degradable hydraulic oil
Tropical hydraulic oil.



ROPS/FOPS with sunroof and halogen working lights.



LED working lights.



Lockable vandal guards.

STATIC DIMENSIONS

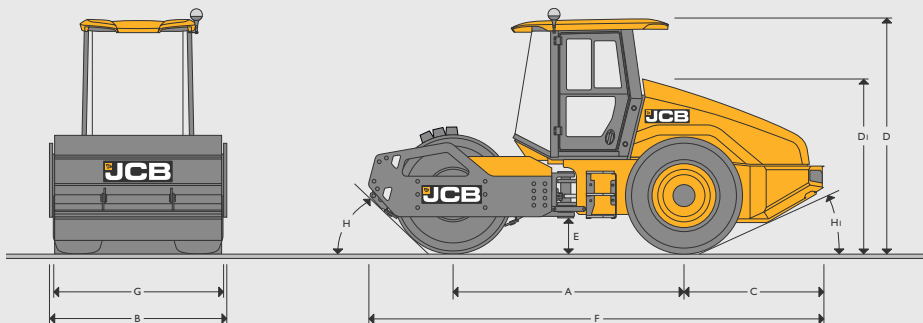

	VM 117 D	VM 117 PD	VM 137 D	VM 137 PD
A Wheelbase	in 115.4	115.4	115.4	115.4
B Overall width	in 87.8	87.8	87.8	87.8
C Axle to rear face	in 69.3	69.3	69.3	69.3
Drum diameter	in 59.1	-	59.1	-
Drum diameter min (Padfoot)	in -	55.1	-	55.1
Drum diameter max (Padfoot)	in -	63	-	63
D Total height with cabin/ROPS	in 9' 10"	10' 1"	9' 10"	10' 1"
D1 Total height without cabin/ROPS	in 7' 5"	7' 7"	7' 5"	7' 7"
E Ground clearance	in 17.5	17.5	17.5	17.5
F Total travel length	in 0.98	0.59	1.18	0.79
Drum thickness	in 25	15	30	20
G Drum width	in 83	83	83	83
H Departure angle front	deg 46	46	46	46
H1 Departure angle rear	deg 32	32	32	32

ENGINE

	VM 117 D	VM 117 PD	VM 137 D	VM 137 PD
Manufacturer	JCB	JCB	JCB	JCB
Model	444/EcoMAX	444/EcoMAX	448/EcoMAX	448/EcoMAX
Displacement	gal 1.16	1.16	1.27	1.27
Bore	in 4.05	4.05	4.17	4.17
Stroke	in 5.2	5.2	5.31	5.31
Torque	lbf/ft 405.7	405.7	413	413
No. of cylinders	4	4	4	4
Cooling	Water	Water	Water	Water
Emmission compliance	T4i Stage IIIb	T4i Stage IIIb	T4i Stage IIIb	T4i Stage IIIb
Performance	hp (kW) 125 (93)	125 (93)	145 (108)	145 (108)
Operating speed	rpm 2200	2200	2200	2200

OPERATING DATA

	VM 117 D	VM 117 PD	VM 137 D	VM 137 PD
Operating weight max.	lbs 29321	29321	32077	32077
Operating weight Cabin	lbs 24912	24912	27668	27668
Operating weight ROPS	lbs 24030	24030	26786	26786
Weight front / rear Cabin	lbs 13669/11244	13669/11244	15873/11795	15873/11795
Weight front / rear ROPS	lbs 13228/10803	13228/10803	15432/11354	15432/11354
Static linear load	lbs/in 165.19	165.19	192.1	192.1
Frequency	vpm 1980/2160	1980/2160	1680/2160	1680/2160
Amplitude	in .07/03	.07/03	.08/04	.08/04
Centrifugal force	lbf 57551/28101	57551/28101	63396/38892	63396/38892
Working speed (forward / reverse)	mph 4.97	4.97	4.97	4.97
Travel speed (forward / reverse)	mph 6.84	6.84	6.84	6.84
Steering angle	deg +/- 35	+/- 35	+/- 35	+/- 35
Oscillating angle	deg +/- 15	+/- 15	+/- 15	+/- 15
Inner turning radius	in 133	133	133	133
Tire sizes	23.1 - 26 / 8 PR AWT	23.1 - 26 / 12 Tractor	23.1 - 26 / 8 PR AWT	23.1 - 26 / 12 Tractor
Number of padfeet	-	132	-	132
Height of padfoot	-	100	-	100
Gradeability up to	% 60	60	60	60

SERVICE CAPACITIES

	VM 117 D	VM 117 PD	VM 137 D	VM 137 PD
Fuel	gal 75.29	75.29	75.29	75.29
Engine oil	gal 3.7	3.7	3.7	3.7
Gear oil (exciter)	gal 2.11	2.11	2.11	2.11
Hydraulic oil	gal 19.81	19.81	19.81	19.81

ELECTRICAL SYSTEM

	VM 117 D	VM 117 PD	VM 137 D	VM 137 PD
Voltage	V 12	12	12	12
Battery capacity	Ah 120	120	120	120
Alternator	V 60	60	60	60



ONE COMPANY, OVER 300 MACHINES.

Your nearest JCB Dealer

Single Drum Soil Compactor VM117/VM137

Operating weight (cabin): 24,912lbs/27,668lbs Engine power: 125-145hp (93-108kW) Drum width: 83in

JCB North American – Headquarters

Savannah, 2000 Bamford Blvd., Savannah, Georgia, 31322 Tel: (912) 447-2000

Download the very latest information on this product range at www.jcb.com

JCB inc. All rights reserved. No part of this publication may be reproduced, stored in a retrieval system, or transmitted in any form or by any other means, electronic, mechanical, photocopying or otherwise, without prior permission from JCB inc. All references in this publication to operating weights, sizes, capacities and other performance measurements are provided for guidance only and may vary dependant upon the exact specification of machine. They should not therefore be relied upon in relation to suitability for a particular application. Guidance and advice should always be sought from your JCB Dealer. JCB reserves the right to change specifications without notice. Illustrations and specifications shown may include optional equipment and accessories. The JCB logo is a registered trademark of J.C. Bamford Excavators Ltd.

