

LGMG

SR4069E

ELECTRIC RT SCISSOR LIFT

- The large platform with high capacity maximizes productivity.
- Battery powered, zero emission and quiet drive mean this machine is environmentally friendly.
- Equipped with oscillating axles that provide excellent performance in soft and rough terrain conditions.
- Hydraulic outriggers deliver a better solution on uneven ground.
- Intelligent self-diagnostic system for quick troubleshooting.

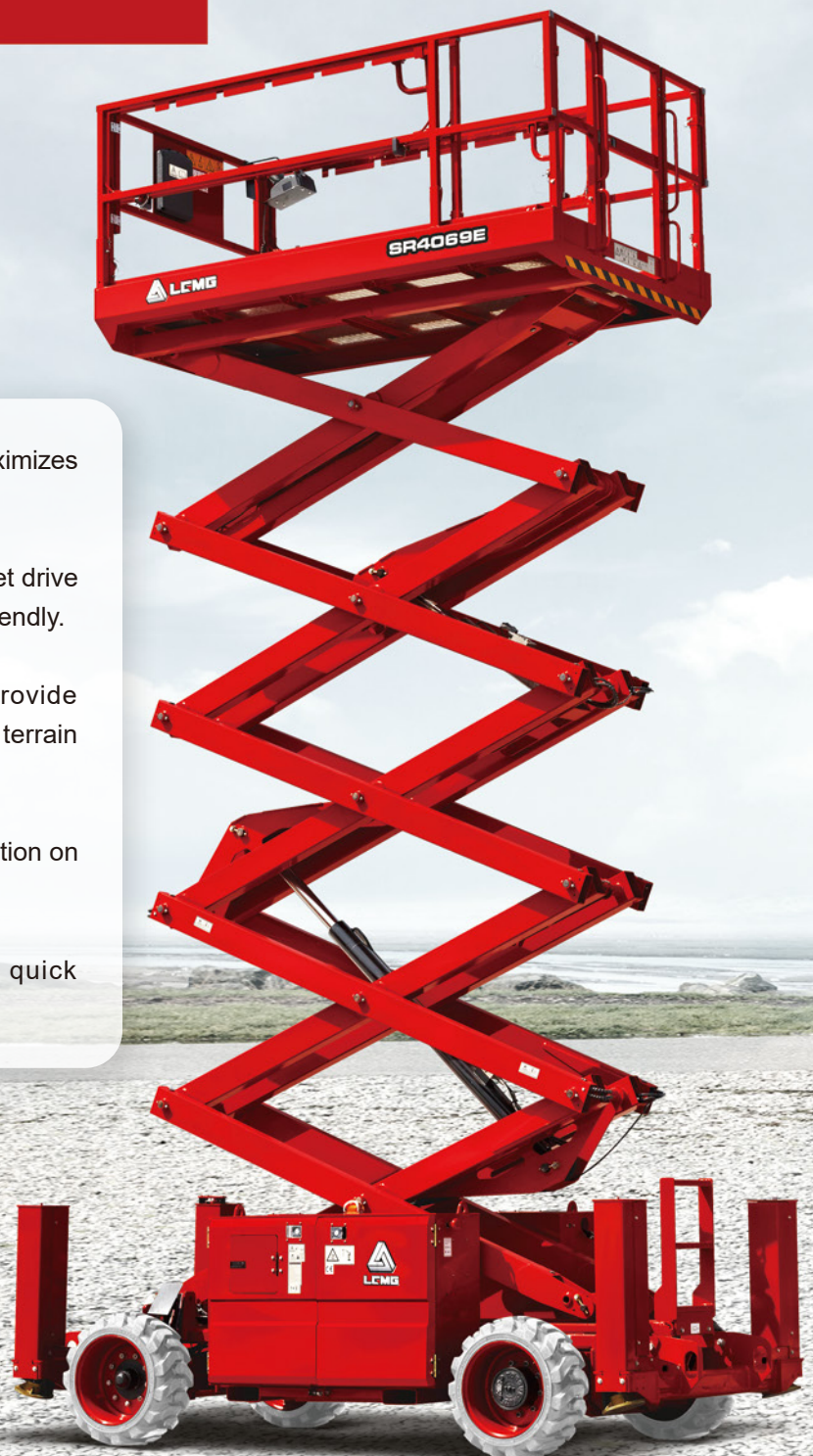

LGMG Electric RT Scissor Lift

SPECIFICATIONS

MODELS	SR4069E (SR1218E)	
Measurements	Imperial	Metric
Work Height Max.	45'7"	13.9m
A Platform Height - Raised	39'	11.9m
B Platform Height - Stowed	5'1"	1.56m
C Platform Length	9'2"	2.79m
D Platform Width	5'3"	1.6m
E Overall Length (with ladder)	12'4"	3.76m
F Overall Width	5'10"	1.79m
G Overall Height - Rails up	8'10"	2.7m
Overall Height - Rails down	6'8"	2.04m
H Extension Deck	5'	1.52m
I Wheelbase	8'	2.29m
Ground Clearance-Center	9"	0.23m

PRODUCTIVITY

Max. Platform Occupancy	3(in) / 2(out)	
Platform Capacity	805 lbs	365kg
Platform Capacity - Extension	310 lbs	140kg
Drive Height	Full Height	
Gradeability - Stowed	35%	
Min. Turning Radius	15'7"	4.75m
Raise/Lower Speed	61 / 55s	
Brakes	Rear-wheel brake	
Drive Mode	4x2	
Tires Type	Foam-filled Non-marking	
Tires Size	26"x11"	663x283mm

POWER

Power Source	48V DC 315Ah	
--------------	--------------	--

HYDRAULIC SYSTEM

Hydraulic Oil Volume	18.5gal	70L
----------------------	---------	-----

WEIGHT

Machine Weight with Outriggers (CE/ANSI)	11245 lbs	5100kg
--	-----------	--------

STANDARD FEATURES

Proportional control	Tilt alarm with lift cut-out
Foldable guardrail	Overload sensing system
Emergency stop device	Descent alarm with flashing beacon
Manual brake release	All motions alarm
Emergency descent	Intelligent diagnostic system
Oscillating axle	Auto-leveling outriggers
Self-lock entry gate	Foam-filled non-marking tires

OPTIONAL

Telematics	Solid tires
AC power to platform	Solid non-marking tires
Biodegradable hydraulic oil	Foam-filled tires

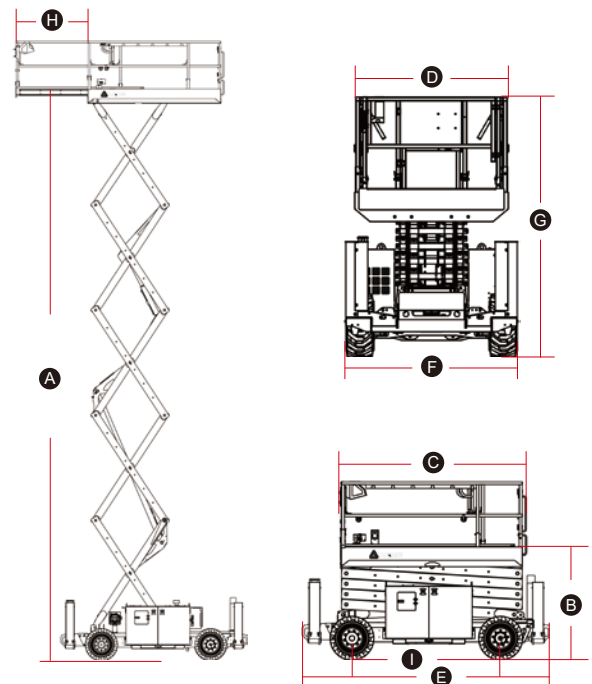

Please contact LGMG or local dealer for more details.

LGMG reserves the right to change technical data without prior notice. All photos and pictures in this brochure are for promotional purpose only. This brochure comes into effect in May, 2023.

LINGONG HEAVY MACHINERY CO., LTD.

Address: No. 2676, Kejia Road, Jinan, Shandong, China
 Email: sales@lmgm.com.cn Tel: +86 531 6787 9283

LGMG Europe B.V.

Address: Donker Duyvisweg 301, 3316 BL Dordrecht, The Netherlands
 Email: sales@lmgmeurope.com Tel: +31 850 642 777

LGMG North America Inc.

Address: 4105 Live Oak Drive, Suite 100, The Colony, Texas 75056 United States
 Email: sales@lmgmna.com Tel: +1 833 288 5464

www.lmgmlifts.com

 **LGMG**
 RELIABILITY IN ACTION