

Installation, Operation and Service Instructions

GAS-FIRED CONSTRUCTION HEATER

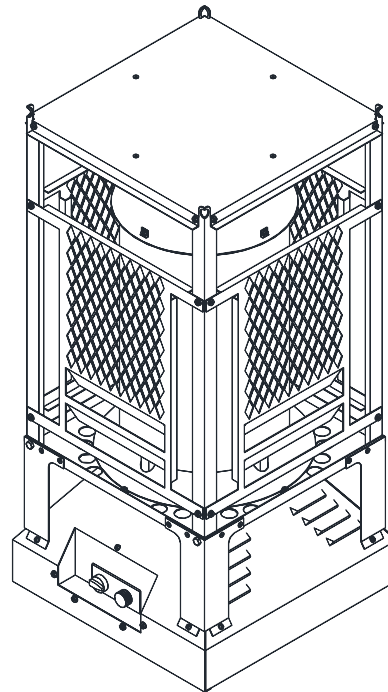

SERIES KA INFRARED



WARNING

Improper installation, adjustment, alteration, service or maintenance can cause property damage, injury or death.

Read the installation, operating and maintenance instructions thoroughly before installing or servicing this equipment.

FOR YOUR SAFETY

Do not store or use gasoline or other flammable vapors and liquids in the vicinity of this or any other appliance.

If you smell gas:

1. Open windows
2. Don't touch electrical switches
3. Extinguish any open flame
4. Immediately call your gas supplier

OWNER

Retain this Manual & ensure available for service.

Improper installation, adjustment, alteration, service or maintenance can cause injury, death or property damage.

Read the installation, operation and service instructions thoroughly before installing or servicing this equipment.

INSTALLER

Provide Manual to Owner upon completion of installation!

Read and thoroughly understand these instructions before attempting any installation.

Canada: 563 Barton St., Stoney Creek, Ontario L8E 5S1

www.irenergy.ca

GENERAL HAZARD WARNING

Failure to comply with the precautions and instructions provided with this heater, can result in death, serious bodily injury and property loss or damage from hazards of fire, explosion, burn, asphyxiation, carbon monoxide poisoning, and / or electrical shock.

Only persons who can understand and follow the instructions should use or service this heater.

If you need assistance or heater information such as an instructions manual, label, etc. contact the manufacturer.

WARNING

Warning: fire, burn, inhalation, and explosion hazard. Keep solid combustibles, such as building materials, paper, or cardboard, a safe distance away from the heater as recommended by the instructions.

Never use the heater in spaces which do or may contain volatile or airborne combustibles, or products such as gasoline, solvents, paint thinner, dust particles or unknown chemicals.

CAUTION: FIRE OR EXPLOSION HAZARD

Warning: Not for home or recreational vehicle use. For use in well ventilated spaces only!

CAUTION

The heater is designed and approved for use as a construction heater in accordance with Standard ANSI Z83.7 CSA 2.14. CHECK WITH YOUR LOCAL AUTHORITY HAVING JURISDICTION IF YOU HAVE QUESTIONS ABOUT APPLICATIONS.

Other standards govern the use of fuel gases and heat producing products in specific applications. Your local authority can advise you about these.

CONTENTS	3
INTRODUCTION	4
INSTALLATION CODES	4
<i>General Installation and Gas Codes</i>	4
<i>Gas Supply Lines</i>	4
GENERAL SPECIFICATIONS	5
CONFIGURATIONS	5
CLEARANCE TO COMBUSTIBLES	6
VENTILATION	7
INSTALLATION SEQUENCE	7
INSTALLATION SEQUENCE	8
OPERATION	9
LIGHTING PROCEDURE	9
ADJUSTING TEMPERATURE	9
SHUT-OFF PROCEDURE	9
MAINTENANCE	10
TROUBLESHOOTING	10
NO GAS SUPPLY.....	10
BURNER DOES NOT LIGHT.....	10
BURNER DOES NOT STAY LIT	10
BURNER DOES NOT STAY LIT	10
REPLACEMENT PARTS	11
WARRANTY	12

INTRODUCTION

IR Energy is a company in the infrared heating industry founded on the principles of product quality and customer commitment.

Quality commitments are evidenced by superior design, a regard for design detail and an upgrade of materials wherever justifiable.

Customer commitment is apparent through our ready responses to market demands and a never-ending training and service support program for and through our distributor network.

IR Energy offers 20 years of experience in specialty infrared equipment design. This construction heater offers a cost effective way of heating a new construction application with an inherent rugged design yielding years of service life and dependability.

Important

These instructions, local codes and ordinances, and applicable standards that apply to gas use comprise the basic information needed to complete the installation, and must be thoroughly understood along with general building codes before proceeding.

Only personnel who have been trained and understand all applicable codes should undertake the hook up and commissioning of this equipment.

Installation Codes

Installations must comply with the national regulations and procedures as listed below.

General Installation and Gas Codes

Heaters must be installed only for use with the type of gas appearing on the rating plate, and the installation must conform to the National Fuel Gas Code, ANSI Z223.1 (NFPA 54) in the US and CAN/CSA B149.1 and B149.2 Installation Codes in Canada.

The heater is designed for use as a construction heater in accordance with ANSI Z83.7/CSA 2.14. Other local standards govern the use of fuel gases and heating products for specific uses. Your local authority can advise you about these. The primary purpose of construction heaters is to provide temporary heating for buildings under construction, alteration or repair. Properly used, the heater provides safe economical heating. Products of combustion are vented into the area being heated. This heater shall be supplied with adequate fresh air.

- Keep appliance area clear and free from combustible materials, gasoline, paint thinner and other flammable vapors and liquids. Dust is combustible. Do not use heater in areas with high dust content.
- Do not install the equipment in an area directly exposed to water spray, rain and/or dripping water.

Gas Supply Lines

Gas supply pipe sizing must be in accordance with the National Fuel Gas Code, ANSI Z223.1 (NFPA 54) in the US and CAN/CSA B149.1 and B149.2 Installation Codes in Canada.

GENERAL SPECIFICATIONS

Gas Supply

Inlet Pressure

Natural Gas:	Minimum	6.0" W.C.
	Maximum	14.0" W.C.
LP Gas:	Minimum	11.0" W.C.
	Maximum	14.0" W.C.

Manifold Pressure

Natural Gas:	5.0" W.C.
LP Gas:	10.0" W.C.

Inlet Connection

Natural and LP Gas: 1/2" (12 mm) Male Quick Connect.

Electric Supply

None required.

Flue and Outside Air Connection

This is an un-vented heater and as such must have adequate ventilation in the building.
(See Warning on Page 7).

CONFIGURATIONS

Model	Maximum Input Rate (Btu/h)	
	Natural Gas	Propane
KA10	100,000	100,000
KA08	80,000	80,000

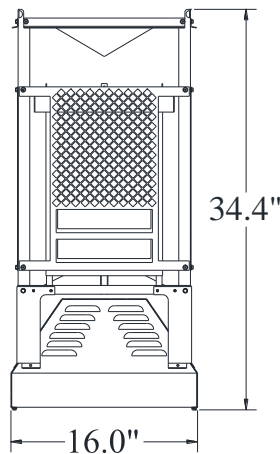

Figure 1: Overall Dimensional Information

CLEARANCE TO COMBUSTIBLES

WARNING

This heater will become too hot to touch. Keep hands and other body parts away from the heater. Always allow the heater to cool down before moving - this may take approximately 20 minutes.

It is important to observe minimum clearance to combustibles at all times to avoid any possibility of property damage or personal injury.

This heater is equipped with a tilt switch. In the event that the heater is knocked over the burner will shut off. The tilt switch will reset when the heater is in the upright position. The pilot will have to be re-ignited. The heater must always be level. Use a level and appropriate shimming to level the heater. This heater may also be supported with chain at the 4 hanging points provided. Clearance to combustibles must always be maintained.

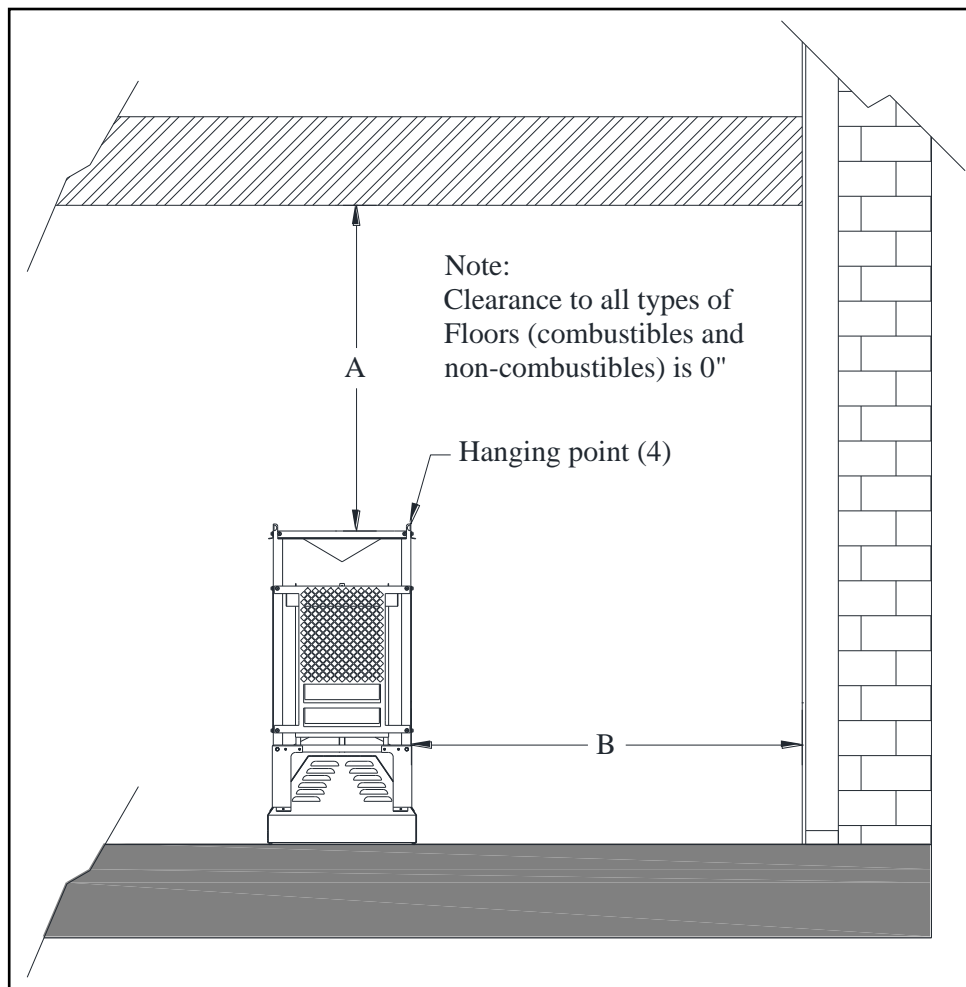

Figure 2: Clearance to Combustibles

MODEL	TOP	ALL SIDES	BELOW
	A	B	
KA 10	32"	42"	0"
KA 08	32"	38"	0"

VENTILATION

Ensure that each heater is provided with adequate fresh air. Check with local authorities and local codes for fresh air requirements.

WARNING

Carbon Monoxide Poisoning: Some people are more affected by carbon monoxide than others. Early signs of carbon monoxide poisoning resemble the flu, with headaches, dizziness, and/or nausea. If you have these signs, the heater may not be working properly. Get fresh air at once! Check for proper ventilation and have heater serviced.

Provide at least a 3 square foot opening of fresh, outside air for each heater while running heater. If proper fresh, outside air ventilation is not provided, carbon monoxide poisoning can occur. Provide proper fresh, outside air ventilation before running heater.

INSTALLATION SEQUENCE

This heater is intended for installation in structures under construction or renovation as a temporary source of heat. This heater shall not be used as a permanent source of heat.

The heater shall be installed such that it is not directly exposed to water spray, rain and/or dripping water.

The gas supply must be installed according to local codes. This heater is equipped with a flexible hose of 15 feet in length. Maximum length allowed in the USA is 25 feet and in Canada is 50 feet. In both cases, an approved gas quick connect is used to allow easy gas disconnect of the gas supply to the heater.

Gas hose lying on the floor shall remain clear and un-obstructed from construction debris. Do not use unapproved gas hose or fittings.

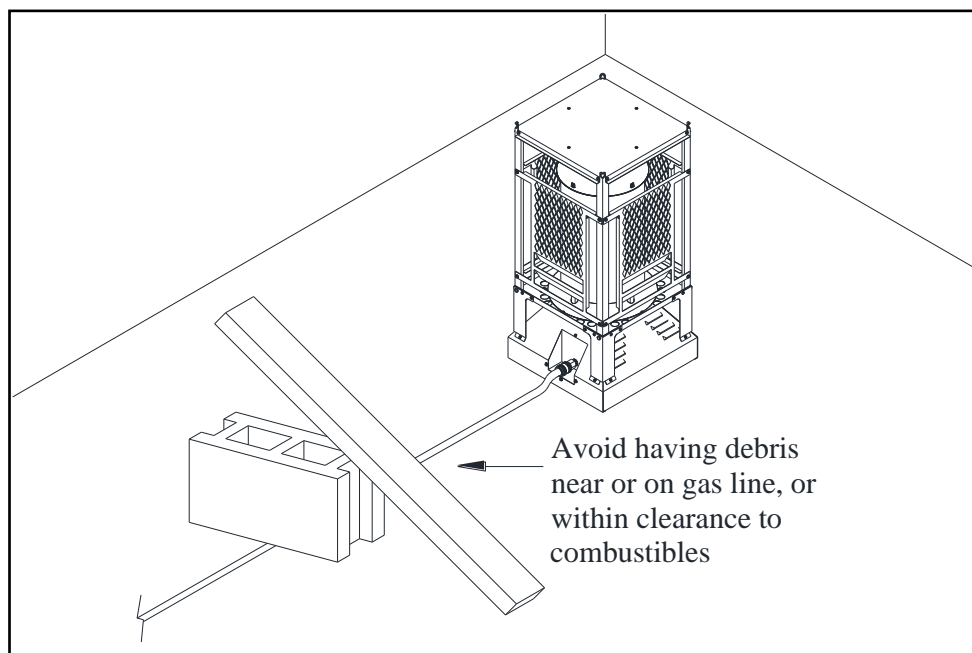

Figure 3

INSTALLATION SEQUENCE

This heater is CSA approved for suspended use. When this heater is suspended it must be suspended as illustrated in Figure 4 below.

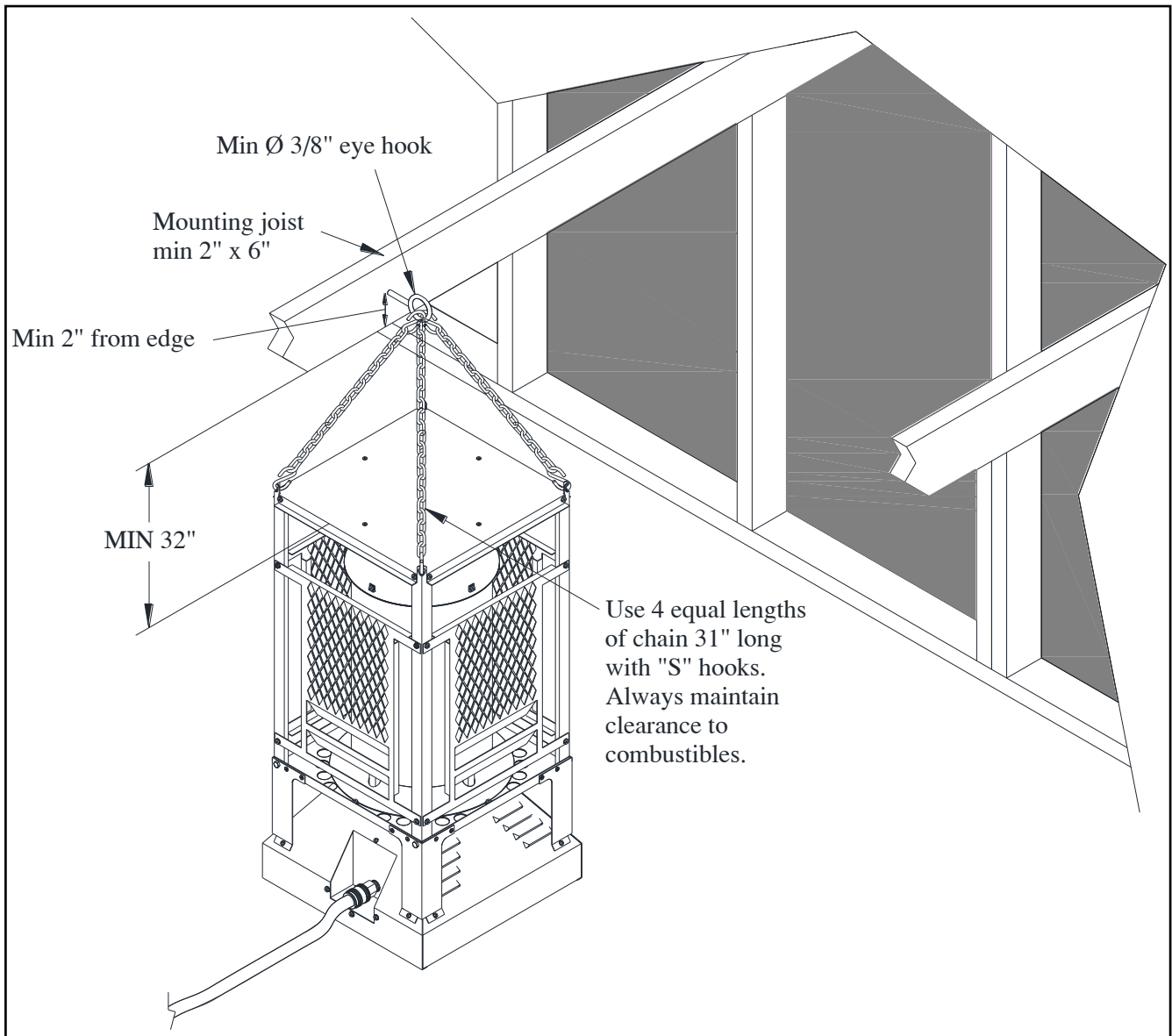

Figure 4

Note: This heater is equipped with a tilt switch. If the heater is knocked over on its side the heater will shut off and you will need to repeat the lighting procedure.

This heater must be located at least: (i) 6 ft. in the U.S.; or (ii) 10 ft. in Canada, from any propane gas container.

This heater shall not be directed toward any propane-gas container within 20 ft.

Lighting Procedure

1. Ensure that a qualified installer has properly purged the gas line.
2. Turn knob A (Figure 4) slightly left towards the ignition position until reaching stop, press down and hold for five seconds (only pilot gas flows).
3. Continue pressing down knob A while turning further left to activate piezo. Continue to hold down for 20 seconds after pilot burner has been lit. If pilot does not light, steps 2 and 3 can be repeated immediately.
4. Upon lighting, release knob and turn further left to ON position. Pilot gas flows and main gas flows in accordance to the temperature, setting (knob B).

Adjusting Temperature

Turn knob B (Figure 5) toward higher numbers to increase and toward lower numbers to decrease temperature.

Shut-off Procedure

1. Turn knob A right until reaching stop. In this position only pilot gas flows to keep the pilot lit for heater stand by.
2. To shut the valve off completely, press down slightly and continue turning right from pilot position to the OFF position, The safety interlock prevents re-ignition of the pilot flame until the thermocouple has cooled down sufficiently (elapsed time will vary based on thermocouple type).
3. Shut off the main Gas supply at the source when the heater is not in use.

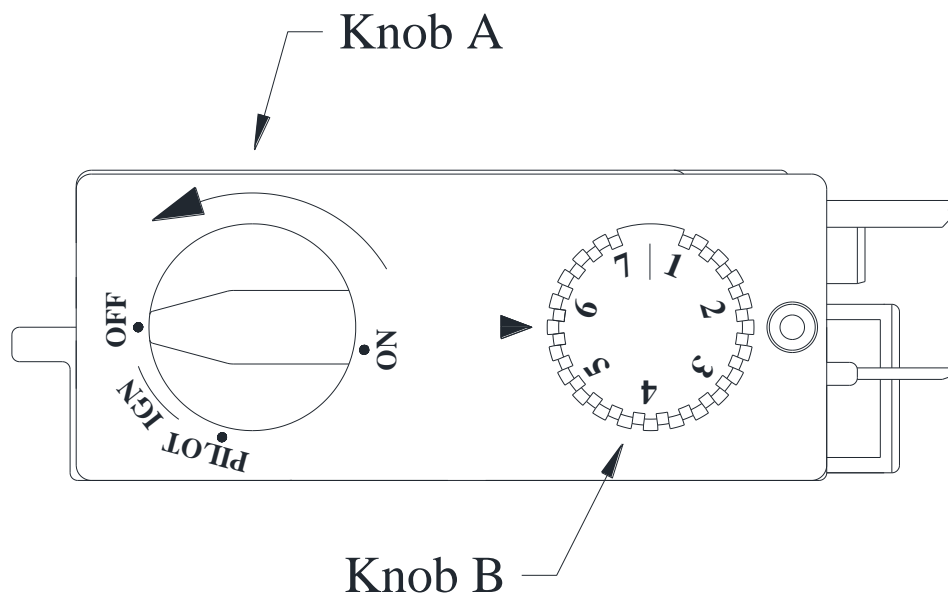

Figure 5

MAINTENANCE

Before each use, this heater should be inspected by an authorized and trained service person.

In order to ensure that the heater continues to run properly the heater must be maintained. From time to time, dust or spider webs may build up on the air flow ports and burner assembly. This can easily be cleaned away with a brush and vacuum or blown away with compressed air. The maintenance frequency will depend on the work environment.

If any physical damage is apparent at any time, consult your local authorized dealer to determine if operation of the heater may be continued safely.

If the pilot is difficult to keep lit, then the thermocouple needs to be cleaned or replaced. Only an authorized service person should perform this task.

The gas hose assembly shall be visibly inspected prior to each use of the heater. If it is evident there is excessive abrasion or wear, or the hose is cut, it must be replaced prior to the heater being put into operation. The replacement hose assembly shall be that specified by the manufacturer.

Ensure that the flow of combustion and ventilation are not to be obstructed.

For replacement parts see page 11.

TROUBLESHOOTING

No Gas Supply

- Ensure that there is sufficient gas supply to the heater
- Ensure that gas valves are open
- Ensure that gas lines have been purged

Burner Does Not Light

- If the pilot is on and the burner does not light, check temperature knob to make sure that it is set high enough. Call authorized service person.

Burner Does Not Stay Lit

- This burner will automatically shut off when the desired room temperature is achieved. This is normal. The heater will automatically relight when the temperature drops below the set point.

Burner Does Not Stay Lit

- Check the supply gas pressure.
- Call authorized service person to adjust pilot and/or maintain pilot assembly

REPLACEMENT PARTS

Item #	Part #	Description
1	KS001	Upper Lid
2	KS014	Handle - Left
3	KS015	Handle - Right
4	KS018	Heat Exchanger
5	KS010	Protective Screen
6	KG003	Nat. Gas Ignition Pilot Assembly
	KG004	L.P. Gas Ignition Pilot Assembly
7	KE001	Tip Over Switch Assembly
8	KG002	Burner
9	KG005	Nat. Gas Orifice (KA10)
	KG006	L.P. Gas Orifice (KA10)
	KG041	Nat. Gas Orifice (KA08)
	KG042	L.P. Gas Orifice (KA08)
10	KG014	1/2" Quick Snap Male Nipple
11		Regulator
12	KG001	Gas Valve

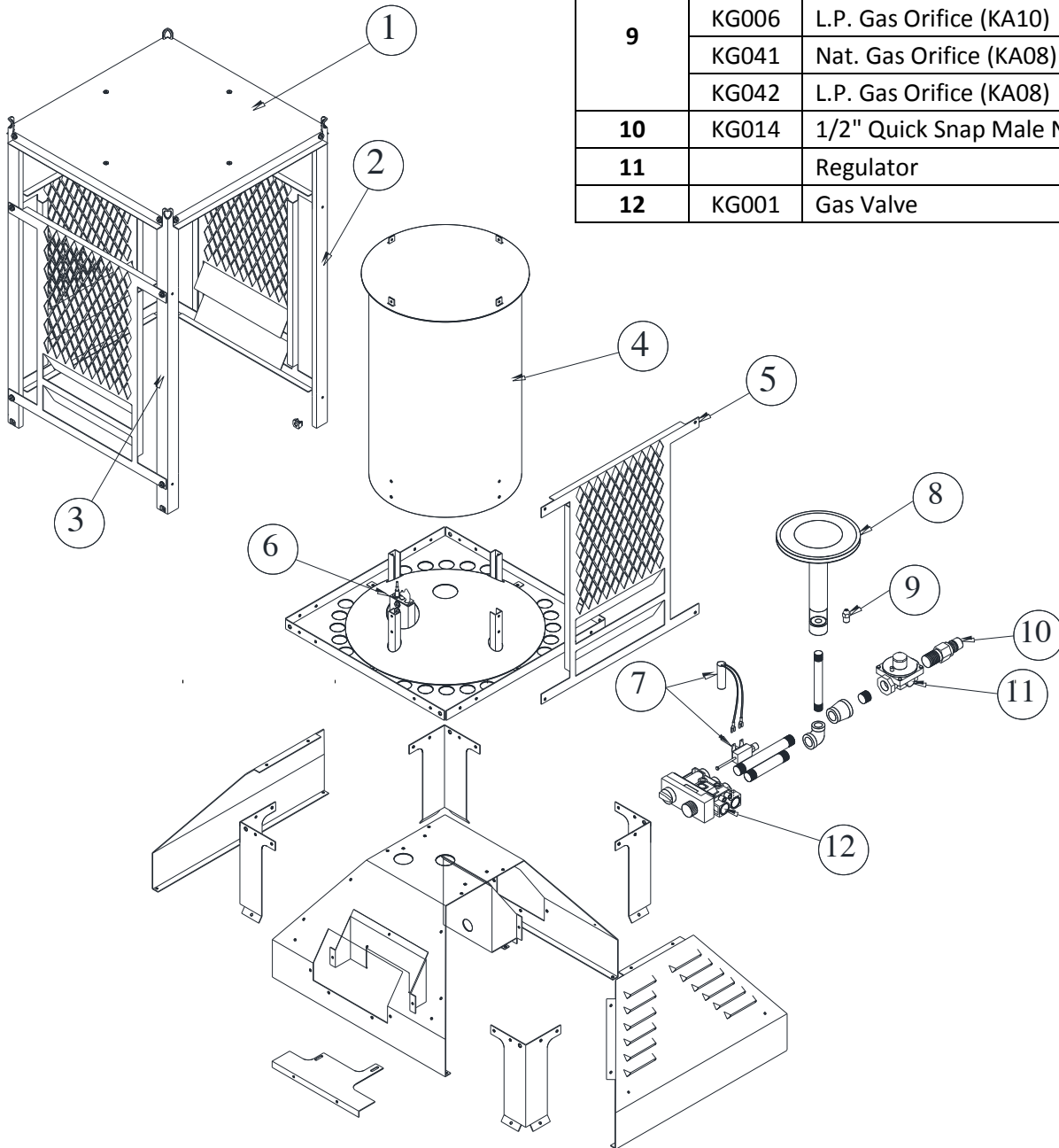

SERIES KA CONSTRUCTION HEATERS

WARRANTY

The manufacturer warrants to the original owner that the product will be free of defects in material and workmanship for a period of one year.

The Manufacturer's obligation under this warranty is limited to repair or replacement, F.O.B. its facility, of the defective part. In the case of replacement parts, the warranty period shall be the longer of the original warranty or a period of 12 months from the date of purchase. In no event shall the Manufacturer be liable for incidental expense or consequential damages of any kind.

This warranty does not cover any shipping, installation or other costs incurred in the repair or replacement of the product. No materials will be accepted for return without authorization.

This warranty will not apply if in the judgment of the Manufacturer, the equipment has been improperly installed, unreasonably used, damaged or modified.

This warranty will not apply to damage to the product when used in corrosive atmospheres and in particular atmospheres containing halogenated hydrocarbons. No person is authorized to assume for the Manufacturer any other warranty, obligation or liability.

THE REMEDIES PROVIDED FOR IN THE ABOVE EXPRESS WARRANTIES ARE THE SOLE AND EXCLUSIVE REMEDIES. NO OTHER EXPRESS OR IMPLIED WARRANTIES ARE MADE INCLUDING, BUT NOT LIMITED TO, ANY IMPLIED WARRANTY OF MERCHANTABILITY OR FITNESS FOR A PARTICULAR USE OR PURPOSE.