

# FROST *Fight*er

**GAS - FIRED CONSTRUCTION HEATER  
PROPANE AND NATURAL GAS**

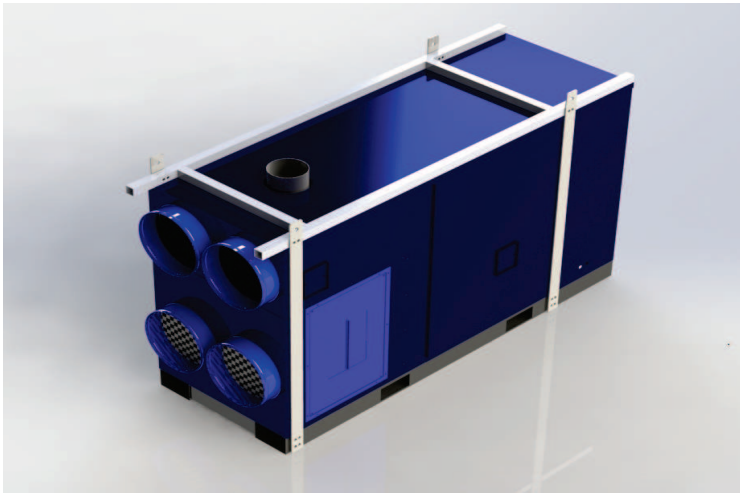

**MODEL IHS 700  
JULY 2008  
TO PRESENT**

**Installation - Operation  
Maintenance Instructions  
and Parts List**

**READ INSTRUCTIONS PRIOR TO STARTING HEATERS**

**FROST** *Fight*er  
PORTABLE HEATERS

FROST FIGHTER INC.  
100-1500 NOTRE DAME  
WINNIPEG, MANITOBA  
CANADA R3P 0E9  
TEL : (204) 775-8252  
FAX: (204) 783-6794  
TOLL FREE: (888) 792-0374



DEC, 2015

**WWW.FROST-FIGHTER.COM**

## FROSTFIGHTER WARRANTY

Frost Fighter Inc. warrants the Frostfighter heater to be free from defects in workmanship and materials for a period of twelve (12) months from date of initial service not to exceed fifteen (15) months from date of shipment.

If during the warranty period, the heat exchanger fails under normal use and service due to a defect in material or workmanship said heat exchanger will be repaired or replace free of charge F.O.B. the Winnipeg Factory..

All mechanical and electrical components are covered by a one (1) year limited warranty. Normal maintenance items are excluded under the warranty. The warranty does NOT include any freight, labor or sales taxes incurred by the purchaser and is subject to the following conditions:

1. The heater shall be operated in accordance with the manufacturer's operating and maintenance manual.
2. The heater shall be subject to normal use in service and shall not have been misused, neglected, altered or other wise damaged.
3. The unit shall be operated within the rated capacities and with the prescribed fuel.
4. The unit has not been allowed to exceed its proper temperature limits due to control malfunction or inadequate air circulation.
5. There is no evidence that the unit has been subject to tampering or deliberate destruction.

No representative of Frost Fighter Inc., nor any of its distributors or dealers, is authorized to assume for Frost fighter Inc. any other obligations or liability in connection with this product, not alter the terms of the warranty in any way. This warranty is limited to the express provisions contained herein and does not extend to liability for labor costs incurred in replacing defective parts.

Parts can be obtained from Frost Fighter Inc., Winnipeg, Manitoba on the basis that credit will be issued if the defective parts returned qualify for replacement pursuant to the terms and conditions of this warranty. Authorization to return any alleged defective parts must be first obtained from the factory prior to transporting the part. The transportation charges for the alleged defective part must be prepaid by the owner. Frost Fighter Inc. will not accept charges for parts purchased unless the conditions of this warranty have been satisfied and prior authorization to purchase the parts has been received from the factory.



100-1500 NOTRE DAME , WINNIPEG, MANITOBA  
R3P 0E9, (204) 775-8252, 1-888-792-0374

**INSTALLATION- OPERATION  
MAINTENANCE INSTRUCTIONS**

**READ INSTRUCTIONS PRIOR TO OPERATING HEATER**

**GENERAL HAZARD WARNING**

FAILURE TO COMPLY WITH PRECAUTIONS AND INSTRUCTIONS PROVIDED WITH THIS HEATER CAN RESULT IN DEATH, SERIOUS BODILY INJURY AND PROPERTY LOSS OR DAMAGE FROM HAZARDS OF FIRE, EXPLOSION, BURN, ASPHYXIATION, CARBON MONOXIDE POISONING, AND/OR ELECTRICAL SHOCK.

ONLY PERSONS WHO CAN UNDERSTAND AND FOLLOW THE INSTRUCTIONS SHOULD USE OR SERVICE THIS HEATING UNIT.

IF YOU REQUIRE ASSISTANCE OR HEATER INFORMATION SUCH AS AN INSTRUCTION MANUAL, LABELS, ETC., CONTACT THE MANUFACTURER.

**WARNING**

FIRE, BURN INHALATION, AND EXPLOSION HAZARD. KEEP SOLID COMBUSTIBLES, SUCH AS BUILDING MATERIAL, PAPER AND/OR CARDBOARD A SAFE DISTANCE AWAY FROM THE HEATER AS RECOMMENDED BY THE INSTRUCTIONS. NEVER USE THE HEATER IN SPACES WHICH MAY CONTAIN VOLATILE OR AIRBORNE COMBUSTIBLES, OR PRODUCTS SUCH AS GASOLINE, SOLVENTS, PAINT THINNER, ACETONE, DUST PARTICLES AND/OR UNKNOWN CHEMICALS.

**WARNING**

THIS PRODUCT IS NOT INTENDED FOR HOME OR RECREATIONAL VEHICLE USE.

**FOR YOUR SAFETY**

DO NOT USE THIS HEATER IN A SPACE WHERE GASOLINE OR OTHER LIQUIDS HAVING FLAMMABLE VAPOURS ARE STORED OR USED.

**GENERAL NOTES:**

STANDARD: ANSI Z83.7 - CSA 2.14

ALL GAS INSPECTION AUTHORITIES IN CANADA REQUIRE THAT THE INSTALLATION AND MAINTENANCE OF HEATER AND ACCESSORIES SHALL BE ACCOMPLISHED BY A QUALIFIED GAS FITTER.

**THE INTENDED USE OF THIS HEATER IS FOR THE TEMPORARY HEATING OF BUILDINGS OR STRUCTURES UNDER CONSTRUCTION, ALTERATION OR REPAIR.**

# INSTRUCTION MANUAL INDIRECT FIRED CONSTRUCTION HEATER

## INSTALLERS RESPONSIBILITY

Installer please note: This equipment has been test fired and inspected. It has been shipped free from defects from our factory. However, during shipment and installation, problems such as loose wires, leaks or loose fasteners may occur. It is the installer's responsibility to inspect and correct any problems that may be found.

## HAZARD DEFINITIONS

The following will be used throughout this manual to bring attention to hazards and their risk factors, or to special information.

**DANGER** Denotes presence of a hazard which, if ignored, will result in severe personal injury, death or substantial property damage.

**WARNING** Denotes presence of a hazard, which, if ignored, could result in severe personal injury, death or substantial property damage.

**CAUTION** Denotes presence of a hazard, which, if ignored, could result in minor personal injury, or property damage.

**NOTICE** Intended to bring special attention to information, but not related to personal injury or property damage.

## To the owner-

**WARNING** Installation and adjustment of the burner requires technical knowledge and the use of combustion test instruments. Do not tamper with the unit or controls. Call your qualified service technician. Incorrect operation of the burner could result in severe personal injury, death or substantial property damage.

Have your equipment inspected and adjusted annually by your qualified service technician to assure continued proper operation.

Never store gasoline or combustible materials near the heating equipment. This could result in explosion or fire, causing severe personal injury, death or substantial property damage.

**WARNING** Never burn garbage or refuse in your heating appliance or try to light the burner by tossing burning material into the appliance. This could result in severe personal injury, death or substantial property damage.

Never restrict air openings on the burner or to the room in which the appliance is located. This could result in fire hazard or flue gas leakage, causing severe personal injury, death or substantial property damage.

## GENERAL NOTES:

1. The heater is designed and approved for use as a construction heater under ANSI Z83.7 CSA 2.14.
2. Frost fighter Inc cannot anticipate every use, which may be made of our heaters. CHECK WITH YOUR LOCAL FIRE AND SAFETY AUTHORITY IF YOU HAVE QUESTIONS ABOUT SAFE APPLICATIONS.
3. Other standards govern the use of fuel gases and heat producing products in specific applications. Your local authority can advise you about this issue.
4. Please retain this instruction manual for future reference.
5. The primary application of this heater is for temporary heating of construction sites and/or applications of this type.
6. Check Rating Plate on heater for set up specifications.
7. For information about replacement parts call toll free 1-888-792-0374

## ELECTRICAL NOTES:

All electrical connections and grounding shall be in compliance with the National Electrical Code, ANSI/NFPA70 and/or the Canadian Electrical Code (CSA Standard C22.1).

## ADDITIONAL INSTRUCTIONS FOR PROPANE GAS:

1. The installation must conform with local codes or in the absence of local codes with the Standard for the *Storage and Handling of Liquefied petroleum Gases, ANSI/NFPA 58* and/or the *National Standards of Canada CAN/CGA B149.2 installation codes for propane gas*.
2. The heater must be located more than ten (10) feet (3.05 meters) away from the propane source or propane tank.
3. When the heater is not in use insure to shut off the gas supply from the propane source or propane tank.
4. Disconnect the heater from the propane source or propane tank when storing the heater indoors.
5. Minimum tank size 400 lbs (360 litres)
6. Connect the tank to the unit using appropriately sized regulators to reduce the tank pressure to 11" w.c.
7. The heater must not discharge toward any propane gas container within 20 feet (6m).

## LIGHTING INSTRUCTIONS IHS 700 (LPNG)

### TO START HEATER

- 1) Securely attach the fuel line to the heater. Maximum fuel supply pressure is 14" W.C. Minimum fuel supply pressure is 7" W.C. (natural gas) and 11" W.C. (propane).
- 2) Check the fuel conversion valve to ensure it is in the proper position. Refer to the label on the heater for proper positioning.
- 3) Connect the electrical power supply. Refer to the heater rating plate for the required voltage.
- 4) Turn on the fuel and electrical supplies. Set the heater selector switch to manual or thermostat and the heater should start.
- 5) If the heater does not start check for proper electrical and fuel supplies. Reset the burner control

### TO STOP THE HEATER

- 1) Turn the heater selector switch to off. The supply fan will continue to run to cool down the heat exchanger.
- 2) To prevent damage to the heat exchanger do not disconnect the power supply until the supply fan stops.

## CONNECTING THE PROPANE TANK

1. The gas connection on the heater is 1" NPT. Ensure you have the proper fittings to connect to the heater.
2. The maximum supply pressure to the heater is 14" W.C. (1/2 PISG).
3. Ensure the proper regulators are installed to reduce the tank pressure to 14"W.C. maximum 11"W.C. minimum.
4. Gas leakage test. Close the main manual valve on the heater and open all manual valves upstream of the heater. Check all connections for leaks with soap solution. Forming of bubbles indicates gas leakage. Retighten or replace connectors as required.

## DISCONNECTING THE PROPANE TANKS

1. Close all fuel valve upstream of the heater including the valve at the tank.
2. Disconnect the fuel lines at the heater and the tank.

## ADJUSTING THE INPUT RATE FOR NATURAL GAS AND PROPANE

Picture 1 shows the location of the manifold test port. To adjust the manifold pressure connect a pressure gauge (0-14" W.C.) to the test port and bring the heater to high fire. Adjust the gas pressure at the regulator (See Picture 2) so the gauge reads the pressure recorded on the rating plate.

Picture 1

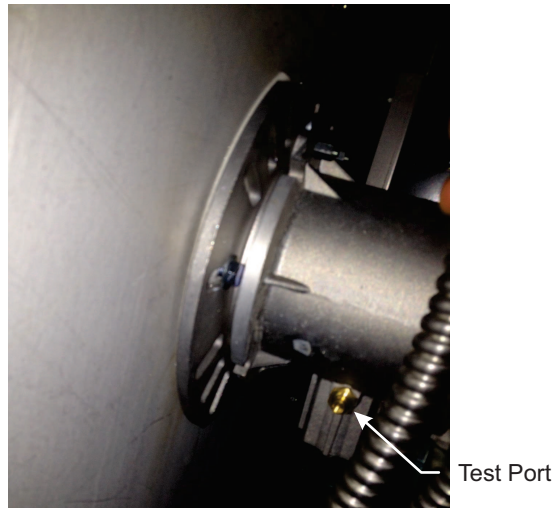

Picture 2

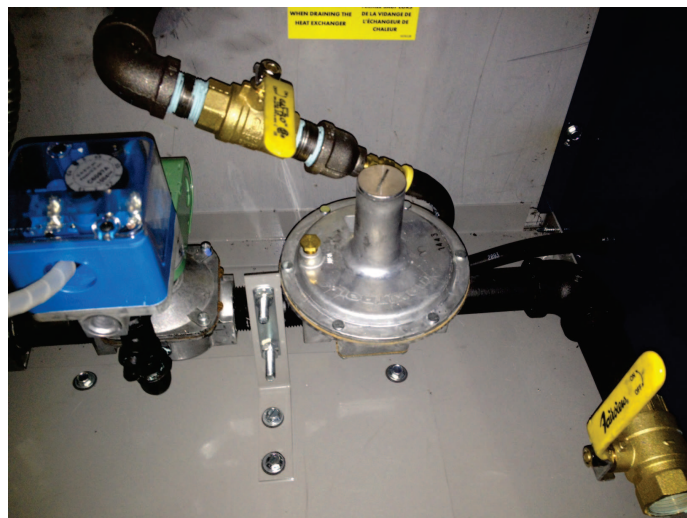

## INSTALLATION INSTRUCTIONS:

1. The installation shall conform with local codes, or, in the absence of local codes, with the *National Fuel Gas Code, ANSI Z223.1/NFPA 54*, or the *National Gas and Propane Installation Code, CSA B149.1*.
2. Inspect the heater before each use and have it annually inspected by a qualified agency.
3. The hose assembly shall be visually inspected prior to each use of the heater. If it is evident there is excessive abrasion or wear, or the hose is cut, it must be replaced prior to the heater being put into operation. The replacement hose assembly shall be specified by the manufacturer. The hose assembly shall be protected from traffic, building materials and contact with hot surfaces both during use and while in storage.
4. When firing the unit in an enclosed area, five square feet (0.47 square meters) must be provided to allow free entry of the air required for operation.
5. Do not operate the unit in partly ventilated areas without a flue pipe connected to the unit.
6. Do not operate the unit in close proximity to combustible surfaces, materials, gasoline, and other flammable vapours and liquids.
7. After installation, check the manifold assembly for gas leaks by applying a water and soap solution to each connection.
8. The heater must be installed on level ground.
9. Minimum gas supply pressure is 7" W.C. (natural gas) or 11" W.C. (propane). Maximum gas supply pressure is 14" W.C. (1/2 PSIG)

## GAS LEAKAGE TESTING

After removal for service or replacing components on the gas manifold a gas leakage test must be performed.

1. Close main gas firing valve on the gas manifold.
2. Connect your source gas to the gas manifold.
3. Once connections are tightened, open source gas, fire unit.
4. On each connection and fitting, apply soap solution and check for bubbles. This will indicate a gas leak if bubbles continue to form.
5. Fix any leaks that are found by applying pipe dope to the leaking fitting or connection and re-tighten. Check for leaks once repairs, if any, are made.
6. Open main gas firing valve and start the unit.
7. Once the unit is operating and burner is running, redo the soap test to insure gas fittings are tight.
8. Fix any leaks found.

## PRE-INSTALLATION CHECKLIST

### LEVELING THE HEATER

- Ensure the surface the heater is to be placed on does not slope more than 5 degrees in any direction.
- If the surface slopes more than 5 degrees either level the surface or place supports under the heater base frame to ensure the heater is level.

### COMBUSTION AIR SUPPLY

The burner requires combustion air and ventilation air for reliable operation. Assure that the Building and/or combustion air openings comply with National Fuel Gas Code NFPA 54/CSA B149. For appliance/burner units in confined spaces, the room must have an air opening near the top of the room plus one near the floor, each with a free area at least one square inch per 1000 Btu/hr input of all fuel burning equipment in the room. For other conditions, refer to NFPA 31 (CSA B1139-M91 in Canada).

If there is a risk of the space being under negative pressure or of exhaust fans or other devices depleting available air for combustion and ventilation, the appliance/burner should be installed in an isolated room provided with outside combustion air.

### CLEARANCES

The unit must be installed with minimum clearances of 6 inches on the sides, 18 inches from the top of the unit, 18 inches from the flue (venting), and 36 inches from the burner access side. The unit must be installed on a level floor.

### DUCT INSTALLATION

- Duct diameter is 16 inches
- Use belt cuff ducting. Slide the cuff overtop of the duct inlet/outlet and tighten with the belt.
- The bottom two duct connections are for cold air or return air in the heater.
- The heater is approved for use with or without ducting.
- Ducts should be rated for 300 F. minimum.



## VENT SYSTEM

The flue gas venting system must be in good condition and must comply with all the applicable codes. The IHS 700 is a category III appliance.

### OUTDOOR INSTALLATIONS:

For outdoor installation a vent cap must be installed and fastened.

### INDOOR INSTALLATIONS:

Must be done in accordance to NFPA 54 (or CSA B149) with local authorities having jurisdictions.

1. The flue must be securely attached to the unit with tight joints.
2. The flue must not be sized to have a cross-sectional area less than that of the flue collar at the unit.
3. Other appliances must not be connected so as to vent through the vent of this unit.
4. Do not use 90-degree tees or elbows greater than 45 degrees, (UNLESS NOTED).
5. Do not support the weight of the stack on the flue connection of the heating system.
6. The maximum flue gas temperature is 550 F. "A" vent, or single wall steel pipe must be used.
7. Minimize connecting pipe length and the number of bends by locating the unit as close to the flue pipe as possible.
8. Maintain clearances between the flue pipe and combustible materials that are acceptable to the Federal, Provincial and local authorities having jurisdiction.
9. Unit must be connected to a flue having sufficient draft to ensure proper operation of unit.

### VERTICALLY VENTED UNITS

1. Maximize the height of the vertical run of vent pipe. A minimum of three (3) feet (1m) of vertical pipe is required. The top of the vent must extend at least two (2) feet (0.61m) above highest point on the roof. A weatherproof vent cap must be installed to the vent termination.
2. Horizontal runs must not exceed 75% of the vertical height of the vent pipe, up to a maximum of ten (10) feet (3m). Horizontal runs should be pitched upward 1/4" per foot (21 mm) and should be supported at 3 foot (1m) maximum intervals.
3. Design vent pipe to minimize the use of elbows. Each 90 is equivalent to 5 feet (1.5m) of straight vent pipe run.
4. Vent pipe should not be run through unheated spaces. If such runs cannot be avoided, insulate vent pipe to prevent condensation inside vent pipe. Insulation should be a minimum of 1/2" (12.7mm) thick foil faced fibreglass, minimum 1 1/2# density.
5. Dampers must not be used in vent piping runs. Spillage of flue gases into the occupied space could result.
6. Vent pressure must be negative.
7. The vent must be terminated vertically.

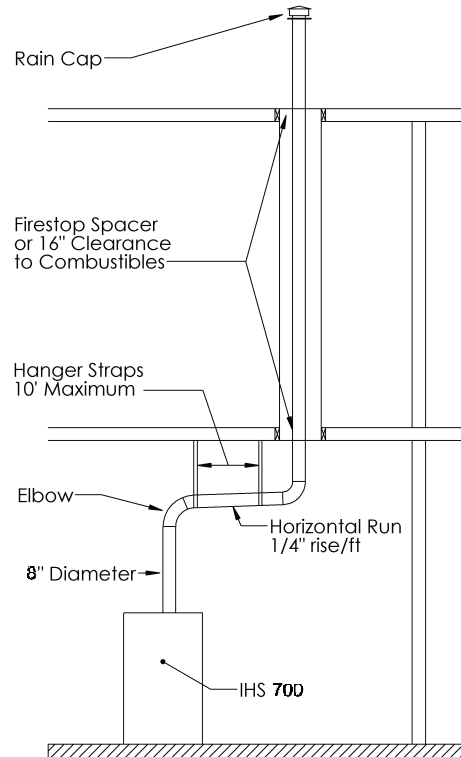

Vent installations shall conform with local codes, or, in the absence of local codes, with the *National Fuel Gas Code, ANSI Z223.1/NFPA 54*, or the *National Gas and Propane Installation Code, CSA B149.1*

## HORIZONTAL FLUE VENTING

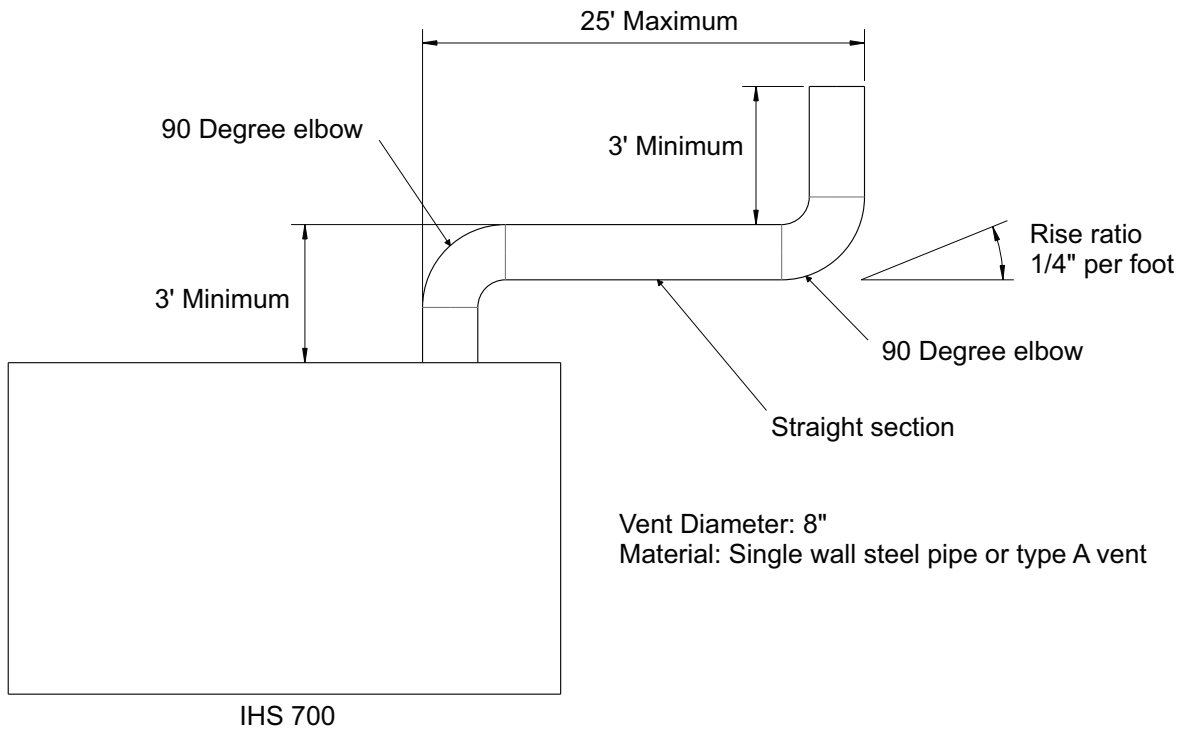

Vent installations shall conform with local codes, or, in the absence of local codes, with the National Fuel Gas Code, ANSI Z223.1/NFPA 54, or the National Gas and Propane installation Code, CSA B149.1

## ELECTRICAL SUPPLY

Verify that the power connections available are correct for the Unit. All power must be supplied through the disconnect.

### INSTALLING THE OPTIONAL THERMOSTAT

Plug the thermostat directly into the receptacle. **WARNING: THE RECEPTACLE IS USED FOR INSTALLING THE THERMOSTAT ONLY! THIS IS NOT A POWER SOURCE.**

### PREPARE THE BURNER FOR START-UP

Start-up checklist – Verify the following before attempting to start burner

- o Combustion air supply and venting have been inspected and verified to be free of obstruction and installed in accordance with all applicable codes.
- o Fuel connection to nozzle line assembly is secure.
- o Fuel supply line is correctly installed, the oil tank is sufficiently filled, and shut-off valves are open.

### START THE BURNER

**WARNING** Do not proceed unless all prior steps in this manual have been completed. Failure to comply could result in severe personal injury, death or substantial property damage.

### AIR SETTING

The air settings should be set at 5 on the right hand side of the burner. The primary air setting should be set at 6 on the main air shutter. In some cases this air-setting needs to be adjusted. To do this insert your flue gas analyzer into the flue, 6 inches above the top of unit. Measure your excess O<sub>2</sub>% and Co<sub>2</sub>% levels. Set your air shutter to bring your O<sub>2</sub>% levels between 4-5%. Your Co<sub>2</sub>% will be between 9-10% and your CO levels should be around zero.

## MAINTENANCE AND SERVICE

### **WARNING**

Operation and adjustment of the burner requires technical knowledge and the use of combustion test instruments. Do not tamper with the burner or controls. Failure to comply could result in failure of the burner or system, resulting in severe personal injury, death or substantial property damage.

Like all precision equipment, your burner will require periodic maintenance.

### ANNUAL SERVICE

Have the burner inspected; tested and started at least annually by a qualified service technician. This annual test/inspection should include at least the following:

- o Clean burner and blower wheel (to remove lint and debris).
- o Test ignition and combustion and verify air damper settings.
- o Test fuel lines and all connections
- o Inspect combustion air and vent systems.
- o Oil motor (if not permanently lubricated).

## MAINTENANCE AND SERVICE cont.

Additionally, you should have the burner checked as indicated below, by your local authorized dealer.

- o Check burner distributor head and mixing plates. Clean if necessary.
- o Check ignition electrode. Clean, adjust or replace as necessary.
- o Check the flame sensor rod (ionization rod) for dirt or carbon build up. Clean, adjust, or replace as necessary.
- o Check manifold gas pressure.
- o Check all burner adjustments.
- o Generally clean all exposed parts and components.
- o Repeat combustion tests.

### EVERY 2 MONTHS

- o If your furnace has an observation port, visually check the flame.
- o Check and clean the air intake louver to remove any buildup of fluff, dust, pet hair, etc.

### MONTHLY MAINTENANCE

- o Observe combustion air openings and vent system for integrity. Openings must be clean and free of obstructions.
- o Check the fuel lines and fittings to verify there are no leaks.
- o Observe burner ignition and performance to verify smooth operation.
- o Shut the system down if you observe abnormal or questionable operation. Call a qualified service agency for professional inspection and service.
- o Grease the main supply blower bearings.

## SEQUENCE OF OPERATION - TYPICAL

### 1. SYSTEM SWITCH "MANUAL" HEAT SWITCH

After a forty second purge period, the burner fires. Thirty seconds after the burner fires the supply fan starts. When the system switch is turned off the burner shuts down and after a three minute cool down period the supply fan shuts down.

### 3. SYSTEM SWITCH "THERMOSTAT" (the Heat Switch is inoperative in this mode)

If a thermostat is used, the thermostat is plugged into the receptacle on the side of the unit. The sensor unit should be placed in the heated space. On a call for heat from the thermostat, after a forty second purge period, the burner fires. Thirty seconds after the burner fires the supply fan starts. When the call for heat from the thermostat is satisfied the burner shuts down and after a three minute cool down period the supply fan shuts down.

### 4. SYSTEM SWITCH "OFF"

The heater is inoperative.

### NOTES:

- When the "VENTILATION SWITCH" is in the "ON" position the supply fan will run continuously.
- When the system switch is turned off the supply fan will continue to run for three minutes to cool down the heat exchanger
- Do not shut down the heater by disconnecting the power supply to the heater as this could damage the heater. To shut down the heater turn the SYSTEM SWITCH to the "OFF" position and wait for the three minute cool down cycle to complete before disconnecting the power supply.

## ELECTRODE AND FLAME PROBE ADJUSTMENTS

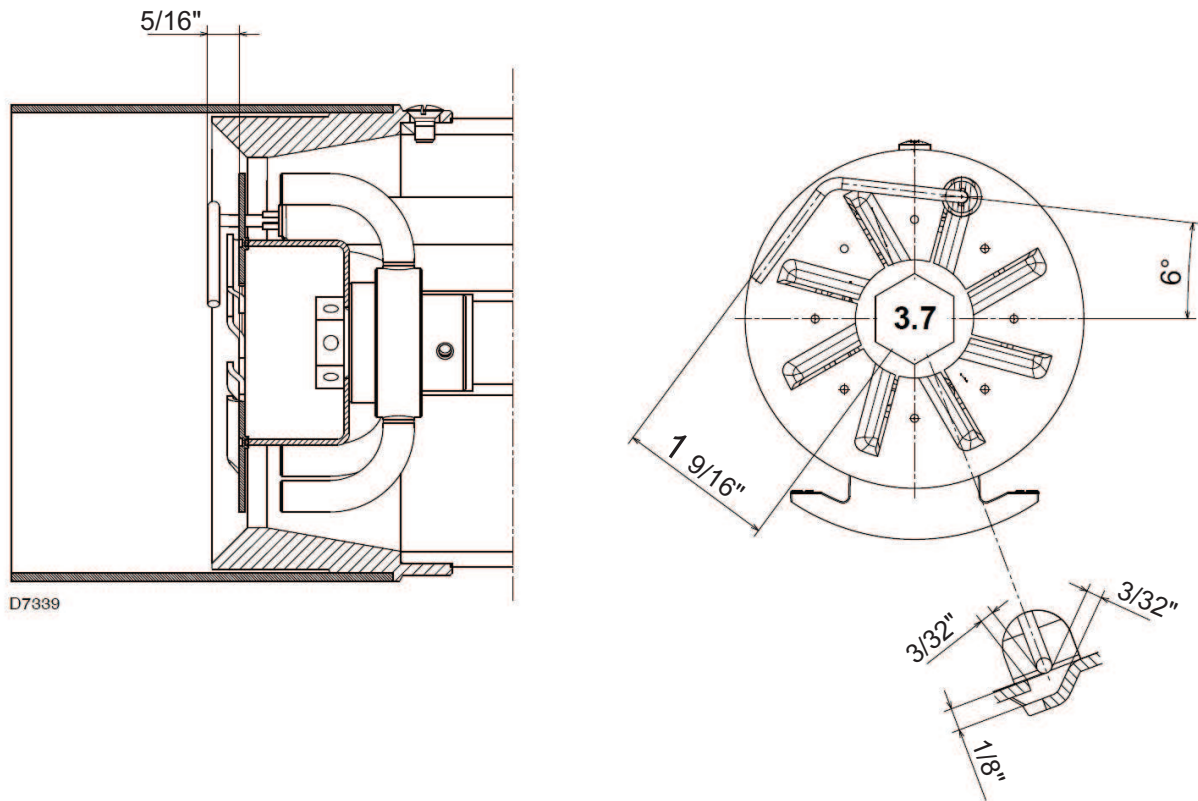

### **WARNING**

Do not turn the ignition electrode. Leave it as shown in the drawing.  
If the ignition electrode is put near the ionization probe, the amplifier control box may be damaged.

## BEARING INSTALLATION AND MAINTENANCE

NOTE: To prevent premature failure – please ensure greasing instructions below are applied. As well, tighten bearing set screws, collars, and wheel lugs every four to six months.

### ENGINEERING – BALL & ROLLER BEARINGS LUBRICATION

For bearings that are equipped with a hydraulic grease fitting threaded into the housing for ease of lubrication, the proper amount of lubricant in the bearing is important. Both excessive and inadequate lubrication may cause failure. The bearings should be re-lubricated while they are rotating (if it is safe to do so); the grease should be pumped in slowly until a slight bead forms around the seals. The bead in addition to acting as an indicator of adequate re-lubrication provides additional protection against the entry of foreign matter and helps flush out contaminants in the bearing.

By the time the slight bead is formed, it will be noticed that the bearing temperature will rise. It is not uncommon for the temperature to rise as much as 30 degrees Fahrenheit after re-lubrication. If necessary to re-lubricate while the bearing is idle, refer to the recommended re-lubrication grease chart tables on the following page for various sizes of the bearings.

### LUBRICANT-STANDARD BEARINGS:

All bearing units are pre-lubricated at the factory with a lithium soap grease which is compatible with multi-purpose grease readily available from local suppliers. The lubricant selected for factory lubrication uses a highly refined mineral oil with a high viscosity index, thickened with lithium soap to conform to NLGI grade 2 consistency. A suitable additive package is added to protect the highly polished rolling contact surfaces from corrosion and oxidation of the lubricant. The lubricant is satisfactory for an operating temperature range of -30 F to +250 F.

Select standard industrial grade greases that conform to the following specification for optimum bearing performance:

General Duty Ball & Roller;  
58-75 SUS @ 210 F  
450-750 SUS @ 100 F

Premium Duty Ball & Roller;  
68-75 SUS @ 210 F  
600-750 SUS @ 100 F

Heavy Duty Roller Bearing;  
82 SUS @ 210 F  
886 SUS @ 100 F

NOTE: For heavy loaded roller bearing applications, grease with EP additives are often recommended for optimum performance.

TABLE I. RECOMMENDED LUBRICATION

Ball Bearings		Roller Bearings	
Shaft Size (inches)	Grease Charge (ounces)	Shaft Size (inches)	Grease Charge (ounces)
1 – 1 ½	0.15	1 – ½ to 1 – 1 1/16	0.32

Frequency of re-lubrication depends upon operating conditions. The bearing operating temperature is the best index for determining a re-lubrication schedule. The following chart gives the frequency of re-lubrication based upon continuous operation for various operating temperatures and can be used as a satisfactory guide for determining when bearings should be re-lubricated.

TABLE II. LUBRICATION FREQUENCY

Speed	Temperature	Cleanliness	Greasing Interval
100 RPM	Up to 120 F	Clean	5 months
500 RPM	Up to 130 F	Clean	2 months
1000 RPM	Up to 210 F	Clean	2 weeks
1500 RPM	Over 150 F	Clean	Weekly
Any speed	Up to 150 F	Dirty	1 week to 1 month
Any speed	Over 150 F	Dirty	Daily to 1 week
Any speed	Any temperature	Very dirty	Daily to 1 week
Any speed	Any temperature	Extreme conditions	Daily to 1 week

## TENSIONING V-BELT DRIVES

1. Ideal tension is the lowest tension at which the belt will not slip under peak load conditions.
2. Check tension frequently during the first 24-48 hours of operation.
3. Over-tensioning shortens the belt and bearing life.
4. Keep belts free from foreign material that may cause slip.
5. Make V-drive inspection on a periodic basis. Tension when slipping. Never apply belt dressing as this will damage the belt and cause early failure.

Check and tighten belt tension. The following procedure is recommended for tightening belts:

- a) Measure span "X" shown in Figure A.
- b) At the center of span length "X", apply a force perpendicular to the span and large enough to deflect belt 1/64" for each inch of span length. Example- the required deflection for a 40" span would be 40/64" or 5/8".
- c) Compare the force applied with the values given in Table III. If force is between the minimum and maximum range shown, the drive tension should be satisfactory. A force below the minimum value indicates an under tightened belt and force that exceeds the maximum value indicates an over tightened belt.

FIGURE A

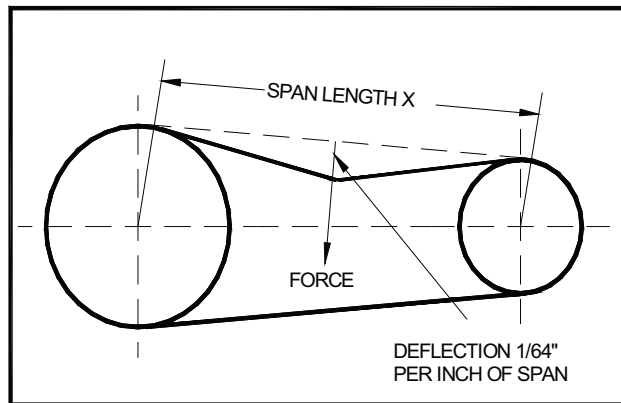

TABLE III

BELT CROSS SECTION (Marked on Belt)	MOTOR PULLEY  PITCH DIAMETER	DEFLECTION FORCE	
		MINIMUM	MAXIMUM
B	4.4" – 5.6"	4.0 lbs.	5.87 lbs.



## TROUBLE SHOOTING GUIDE

The equipment has been electrically and fire tested prior to shipment. However, during transit, misadjustment of controls and loose wires could develop. Do not assume a control is defective until it and its associated wiring is checked.

This equipment has many items supplied to us by outside vendors. This manual is accompanied by information sheets on most of these items which should be referred to for detailed service information.

The following is an obvious list of items that could cause field problems; however, it does not cover all problems encountered and is meant to be used as a guide only.

### 1. BURNER MOTOR FAILS TO RUN, CONTROL RELAY DOES NOT FUNCTION:

- A. Blown fuses. Main disconnect open.
- B. Control relay off on flame failure. Push reset button on control.
- C. Thermostat or duct stat not calling for start-up. Defective control.
- D. Loose wire or low voltage.
- E. Motor overcurrent protector tripped in open position or defective.
- F. Controls in limit circuit defective or tripped in open position.
- G. Control transformer defective.

### 2. BURNER MOTOR RUNS, NO IGNITION OR MAIN FLAME. PRIMARY RELAY WILL NOT INDICATE FLAME FAILURE.

- A. Burner motor running backwards.
- B. Misadjusted or defective burner air switch.

### 3. BURNER MOTOR RUNS, NO IGNITION OR MAIN FLAME. PRIMARY RELAY LOCKS OUT ON FLAME FAILURE.

- A. Fuel valve manually closed.
- B. Ignition transformer or pilot defective. Defective or improperly gapped ignition electrodes. Cracked porcelain.
- C. Low gas pressure switch tripped.

### 4. BURNER MOTOR RUNS, IGNITION AND MAIN FLAME. MAIN FAN MOTOR FAILS TO OPERATE.

- A. Fan timer not set properly or defective.
- B. Blown fan fuses.
- C. Motor overcurrent protector tripped open or defective.

### 5. INSUFFICIENT HEAT BEING DISCHARGED INTO AREA:

- A. Main fan blowers running backwards.
- B. High limit switch defective.
- C. Field mounted thermostat and/or duct stats improperly wired.

## BURNER STARTING DIFFICULTIES AND THEIR CAUSES:

1. The burner goes to lockout after the prepurge period because the flame does not ignite.
  - a. Air has not been fully evacuated from the gas lines.
  - b. The gas valve is passing too little gas.
  - c. The ignition spark is irregular or not present.
  - d. The gas valve is defective.
2. The burner does not start when there is a call for heat.
  - a. The air pressure switch has failed.
  - b. There is no gas, or insufficient pressure in the supply lines to activate the optional gas pressure switch (if used).
  - c. There is a blown fuse.
  - d. The burner has gone off on safety.
  - e. The low voltage contacts or the low voltage relay are defective.
3. The burner goes through prepurge, ignition is established, the burner fires for 2 seconds, then goes to lockout.
  - a. The flame rectification rod (flame rod) has shorted to ground or is defective.
  - b. Polarity is reversed or the earth ground is not properly connected.
  - c. The ionization current is weak (lower than 2 micro-amps).

## OWNER INFORMATION

### SAFETY LOCKOUT

This burner is equipped with multiple interlocking safety devices. In the event of a failure in the flame, or any blockage of the combustion air supply, the burner will "lock out" in a safety condition. In such an event, an illuminated red button will show on the flame safeguard.

To restart the burner, press the button once only. Should the burner return to the lock out condition, call a qualified service technician or your gas company for assistance. In the case of loss of pressure in the gas supply line, the burner will go off on safety. If supplied with an optional gas pressure switch (or field installed), the burner will simply switch off on low gas pressure, and start up again when the gas pressure returns to normal.

NOTE: Keep the area around the burner free and clear of all combustible materials, gasoline and other flammable vapours and liquids. Do not allow any obstructions, which may prevent the free, flow of air to the burner.

## START-UP CYCLE DIAGNOSTICS

During start-up, indication is according to the following table:

COLOUR CODE TABLE

<u>Sequences</u>	<u>Colour Code</u>
Pre-purging	• • • • • • • • • • •
Ignition phase	• ○ • ○ • ○ • ○ • ○ •
Operation, flame ok	□ □ □ □ □ □ □ □ □ □ □
Operating with weak flame signal.	□ ○ □ ○ □ ○ □ ○ □ ○
Electrical supply lower than – 100V	• ◆ • ◆ • ◆ • ◆ • ◆ •
Lock-out	◆ ◆ ◆ ◆ ◆ ◆ ◆ ◆ ◆ ◆
Extraneous light	◆ □ ◆ □ ◆ □ ◆ □ ◆ □ ◆
<u>Index: ○ Off • Yellow □ Green ◆ Red</u>	

## RESETTING THE CONTROL BOX AND USING DIAGNOSTICS

The control box features a diagnostics function through which any causes of malfunctioning are easily identified (indicator: RED LED).

To use this function, you must wait at least 10 seconds once it has entered the safety condition (lock-out), and then press the reset button. The control box generates a sequence of pulses (1 second apart), which is repeated at constant 3-second intervals.

Once you have seen how many times the light pulses and identified the possible cause, the system must be reset by holding the button down for between 1 and 3 seconds.

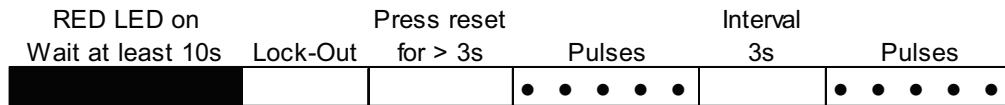

The methods that can be used to reset the control box and use diagnostics are given below.

### RESETTING THE CONTROL BOX

To reset the control box, proceed as follows:

- Hold the button down for between 1 and 3 seconds. The burner restarts after a 2-second pause once the button is released. If the burner does not restart, you must make sure the limit thermostat is closed.

### VISUAL DIAGNOSTICS

Indicates the type of burner malfunction causing lock-out.

To view diagnostics, proceed as follows:

- Hold the button down for more than 3 seconds once the red LED (burner lock-out) remains steadily lit. A yellow light pulses to tell you the operation is done. Release the button once the light pulses. The number of times it pulses tells you the cause of the malfunction, indicated in the table below.

### SOFTWARE DIAGNOSTICS

Reports the life of the burner by means of an optical link with the PC, indicating hours of operation, number and type of lock-outs, serial number of control boxes, etc...

To view diagnostics, proceed as follows:

- Hold the button down for more than 3 seconds once the red LED (burner lock-out) remains steadily lit. A yellow light pulses to tell you the operation is done.

Release the button for 1 second and then press again for over 3 seconds until the yellow light pulses again. Once the button is released, the red LED will flash intermittently with a higher frequency: only now can the optical link be activated.

Once the operations are done, the control box's initial state must be restored using the resetting procedure described above.

<b>BUTTON PRESSED FOR</b>	<b>CONTROL BOX STATUS</b>
Between 1 and 3 seconds	Control box reset without viewing visual diagnostics
More than 3 seconds	Visual diagnostics of lock-out condition (LED pulses at 1-second intervals)
More than 3 seconds starting from the Visual diagnostics condition	Software diagnostics by means of optical interface & PC (hours of operation, malfunctions, etc. can be viewed)

## RESETTING THE CONTROL BOX AND USING DIAGNOSTICS cont.

The sequence of pulses issued by the control box identifies the possible types of malfunction, which are listed in the table below.

SIGNAL	PROBABLE CAUSE
2 pulses ••	The flame does not stabilise at the end of the safety time : -faulty ionization probe; -faulty or soiled gas valves; -neutral/phase exchange; -faulty ignition transformer -poor burner regulation (insufficient gas).
3 pulses •••	Minimum air pressure switch does not close: -make sure VPS trips to produce lockout; -air pressure switch faulty; -air pressure switch incorrectly regulated; -fan motor does not run; -maximum air pressure switch operating.
4 pulses ••••	Min. air pressure switch does not open or light in the chamber before firing: -air pressure switch faulty; -air pressure switch incorrectly regulated.
7 pulses •••••••	Loss of flame during operations: -poor burner regulation (insufficient gas); -faulty or soiled gas valves; -short circuit between ionization probe and earth.
10 pulses ••••• •••••	-Wiring error or internal fault.

EXPLODED SPARE PARTS

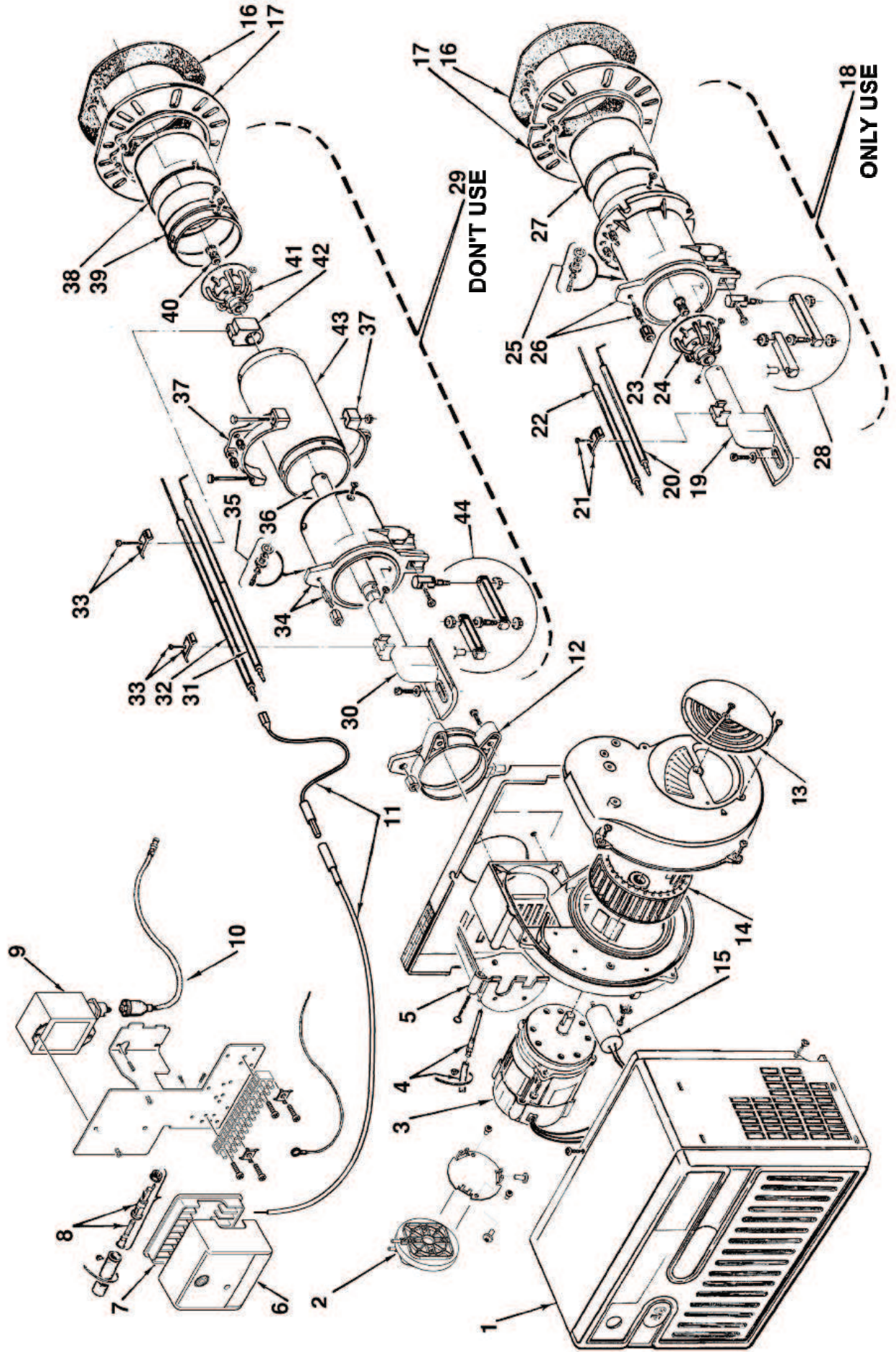

## IHS 700 Wiring Panel

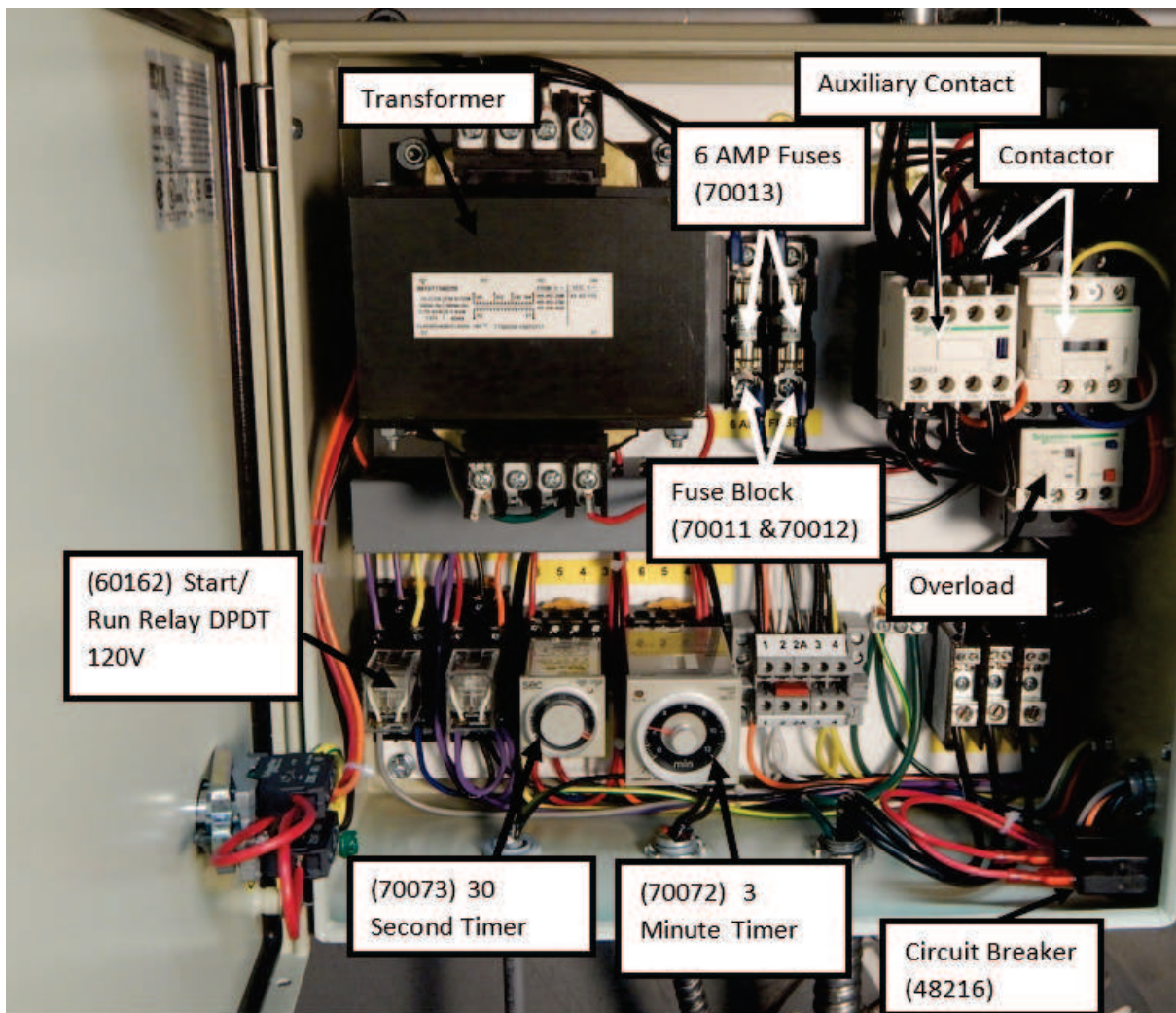

# Manifolds

## IHS 700

- |   |                           |       |   |                               |        |
|---|---------------------------|-------|---|-------------------------------|--------|
| 1 | 1" shut off ball valve -  | 70034 | 2 | 1" Conversion valve -         | 70034A |
| 3 | Dungs shut off solenoid - | 70275 | 4 | Low pressure gas switch -     | 70058  |
| 5 | Asco shut off solenoid -  | 70274 | 6 | Maxitrol 1/2 psig regulator - | 700931 |

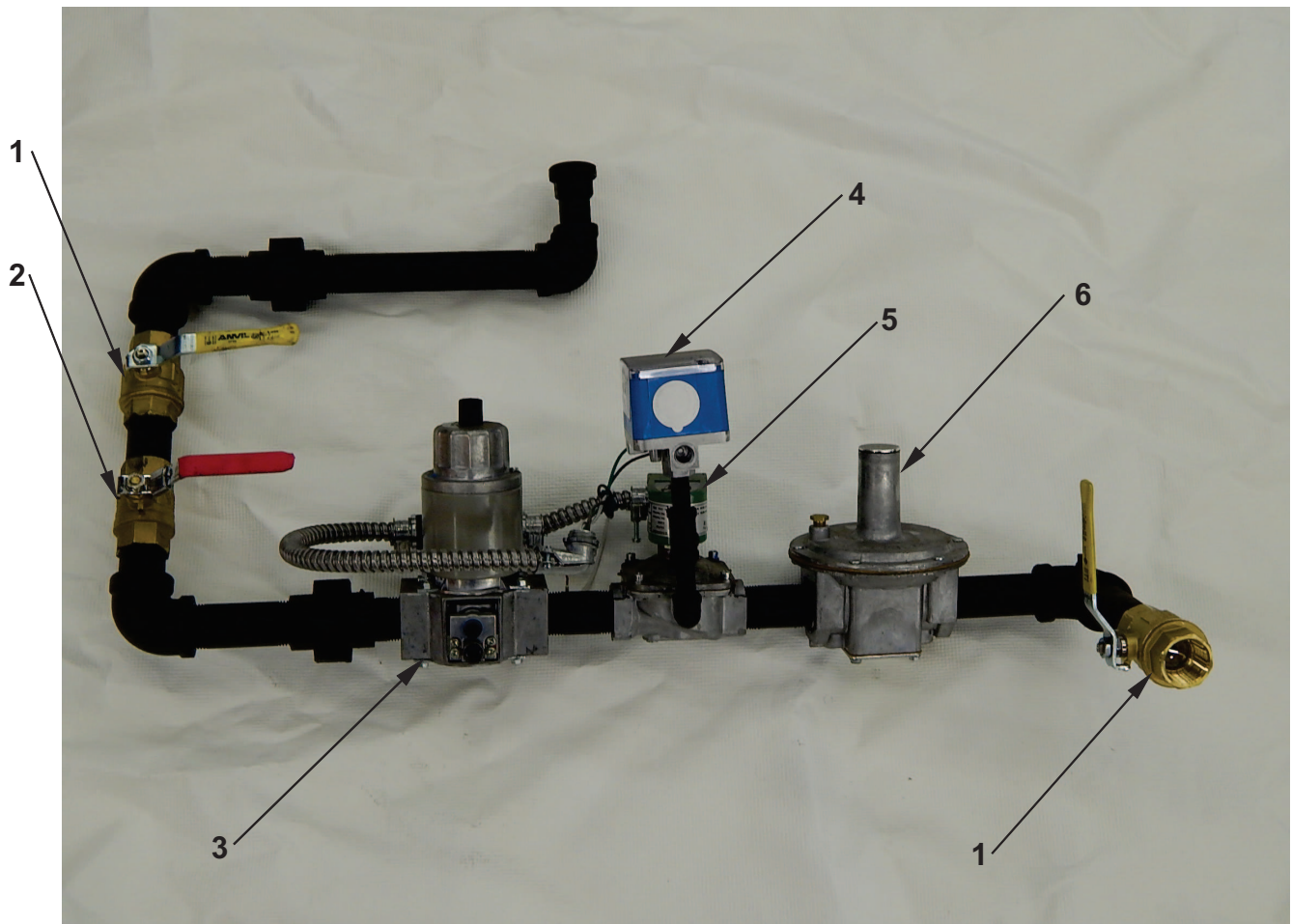

# IHS-700 LPNG WIRING SCHEMATIC

