

Portable Heat Exchangers

Models 80, 200 and 600



Features

- Ideal for heating, drying and climate control applications.
- Their compact and mobile design allows them to be positioned where required on the job site.
- The efficient fan/coil design provides a high rate of heat transfer with built-in, high volume fans provide the heat delivery.
- High volume air flow ensures;
 - when heating... even heat distribution throughout the structure
 - when drying... required air flow to effectively exhaust moisture-laden air from the structure.
 - Clean, low humidity heat delivery minimizes energy costs. With the DRYAIR system, you just recirculate and re-heat warm internal air, rather than heating cold external air.
- Provides the low humidity environment control essential for inhibiting mold growth.
- Provides the optimum project application environment for interior finish work.
- Allows for daily application of joint compound or finish texture to drywall.
- Minimizes expansion and contraction of wallboard.
- Reduces amount of downtime between finished drywall and paint application.

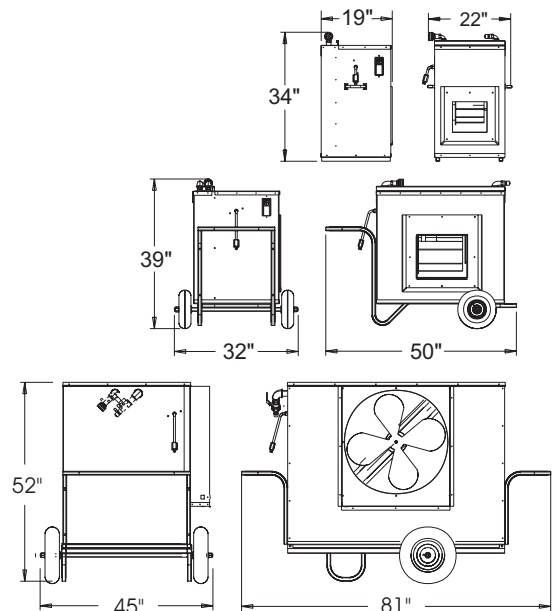

- Eliminates shading of paint caused by residue from open flame heaters.
- Allows better adhesion of caulking materials.
- Provides a drier surface for application of water-based carpet and tile adhesives, epoxy and urethane coatings and epoxy joint fillers.
- Reduces the chance of shrinkage at mitered joints in finish trim materials.

Specifications

	Model 80	Model 200	Model 600
Blower	G Series double inlet	G Series double inlet	Axial flow
Motor	1/4 HP, 3-speed	1 HP, 3-speed	1 HP, 3-speed
Volts	120 V, single phase, 60 Hz		
Amps	3.7 / 3.1 / 2.4	12.7 / 7.0 / 4.3	12.7 / 7.0 / 4.3
Controls	thermostatic temperature control	thermostatic temperature control	n/a
Fluid circulation features			
Coil			
Physical properties	2-row copper tube, aluminum fin	3-row copper tube, aluminum fin	3-row copper tube, aluminum fin
BTU output	Based on 200°F (93°C) supply fluid and 32°F (0°C) ambient air		
	80,187 BTU/H with 900 CFM air flow	201,364 BTU/H with 2,300 CFM air flow	512,418 BTU/H with 5,000 CFM air flow
	and 6 GPM fluid flow	and 15 GPM fluid flow	and 30 GPM fluid flow
Circulation	single supply & return		
Fluid connection	3/4" hydraulic style quick-couplers	1" hydraulic style quick-couplers	1 1/4" hydraulic style quick-couplers
Circulation lines			
Fluid lines	300 P.S.I. heavy-duty "Explorer Air" hose		
	3/4" I.D. x 50' (15.2 M)	1" I.D. x 50' (15.2 M)	1 1/4" I.D. x 50' (15.2 M)
Couplers	3/4" hydraulic style quick-couplers		
	1" hydraulic style quick-couplers	1 1/4" hydraulic style quick-couplers	1 1/4" hydraulic style quick-couplers
Weight	90 LBS. (41 KG.)	210 LBS. (95 KG.)	560 LBS. (254 KG.)
Options			
Humidistat	Humidity controller		
Sky hook	n/a	bolt-on	n/a



Heat Thaw Cure Dry