

Central Heating Module

Model 2100-0900



Features

- Diesel / light oil fired system
- Temperature control and fuel usage is automatic.
- includes unique "Climate Control" system which ensures efficient and reliable burner operation in all conditions
- Compact and portable design for easy positioning on the work site.
- All system operation is controlled and monitored from the central heating module control panel
- 8-light system operation feature for easy system troubleshooting.
- Fluid circulation system is low pressure and atmospherically vented. There is no chance of an explosion or line burst due to pressure build-up. No special boiler certification is required to operate the system.
- Quick-connect hose couplers, "no-drain" fluid lines and a "rapid air elimination" feature ensures quick setup-and-go operation.
- A transport trailer is available and is specifically designed to carry the Dryair 2100-900 central heating module.
- Trailer has a built-in lock box for enclosing an optional portable generator.
- Add an optional diesel-powered genset for complete self-contained operation on a non-powered site.
- Conforms to most special job requirements due to its modular nature.

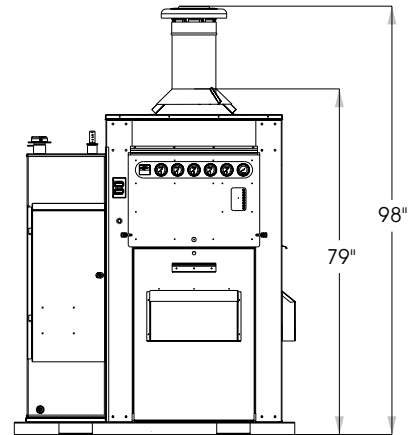
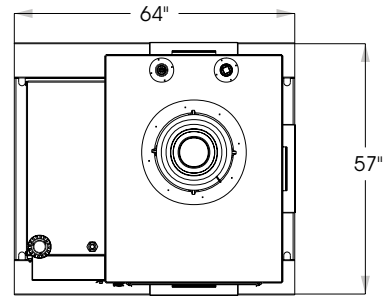

Specifications

.....	- Two stage, Diesel fuel/#1 or 2 heating oil, 85% efficientCombustion air heater	- Automatically maintains set combustion air temperature. Fluid (hot glycol)-to-air heat transfer utilizing a heat transfer coil.
Input capacity	- 896,000 BTU/H, 260 KW/H	Control & monitoring	- Pump & temperature controls. Full gauge panel showing circulation fluid temperatures & pressures, fuel pressures and 8-light system operation feature for easy system troubleshooting.
Output capacity	- 761,600 BTU/H, 221 KW/H	Internal fluid circulation system	
Fuel consumption	- 6.4 US GPH, 24.2 LPH, 20.7 KG/H	Basic features.....	- Atmospherically vented & low pressure, single supply & return, adjustable fluid temperature control, auto pressure bypass for pump protection and variable flow demands, auto temperature bypass for heat exchanger protection.
Weight.....	- Dry - 2,800 LB., 1,270 KG	Circulation pump	- RPM - 2900
Electrical	- Wet - 4,100 LB., 1,860 KG	- 2 HP., 1.5KW
.....	- Single phase, 115/230 V, 60 Hz, 30 Amps	- Flow - 80 US GPM @ 30 P.S.I., 16 M ³ /HR @ 21 M W.C.
Loading - standard.....	- Forklift pockets on all sides	Primary circulation.....	- Fluid circulation lines - 2", 50 MM
Heat exchanger.....	- Water jacket / fire tube type	- Ball valves - 2", 50 MM
.....	- Fluid volume - 45 US Gal., 170 L	Heat transfer fluid (HTF)	- Kamlock quick couplers - 2", 50 MM
.....	- Fluid temp. range - 120°F to 200°F, 49°C to 93°C	Lock-out package	- Locks out primary "supply" & "return" fluid circulation valves and control panel
Fuel tank	- Welded steel	Optional	
.....	- Fuel capacity - 187 US GAL., 708 L	Transport trailer	
.....	- 29 hrs operating range at full output	Generator	- Diesel
Climate control system	- Maintains optimum burner reliability and efficiency at a full range of ambient temperature conditions. Assures system start-up and operation in all conditions.		
Before system start-up			
....Pre-heater	- 4000 Watt electric circulation heater, 230V, preheats heat exchanger glycol before system start-up.		
During system operation			
....Fuel heater.....	- Automatically maintains set fuel temperature. Fluid (hot glycol)-to-fluid (fuel) heat transfer.		



Heat Thaw Cure Dry

2100-0900 050802 US-UK

DRYAIR INC. 606 Highway Drive, St.Brieux, SK., Canada, SOK 3V0
 Tel: (306) 275-4848, 1-888-750-1700, Fax: (306) 275-4664
 E-mail: dryair@dryair.ca Web: www.dryair.ca

DRYAIR INC. 1095 N. Main Street, Bowling Green, Ohio, USA, 43402
 Tel: (419) 354-8546, 1-866-354-8546, Fax: (419) 354-9706
 E-mail: dryair@dryair.us Web: www.dryair.us