



Installation & Commissioning Instructions

Product: REGULATOR WITHOUT RELIEF VALVE

Data Sheet No: CIC 9001A

Issue Date: October 2006

GENERAL INFORMATION

EQUIPMENT DIAGRAM AND LABELLING

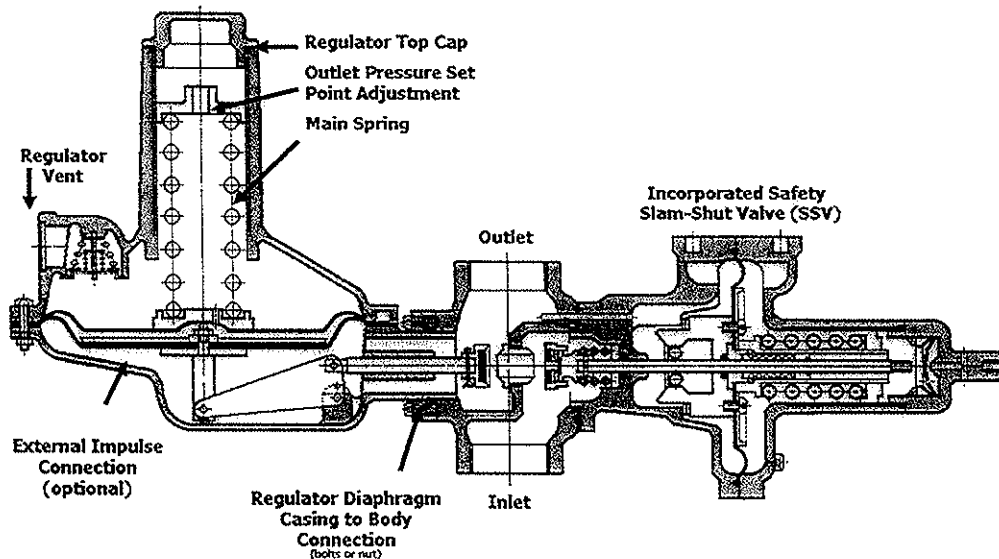

- Technical information will be found on the regulator adhesive label or metal badge usually on the main spring housing of the diaphragm casing
- Information - model number, factory outlet pressure setting, factory safety valve setting, orifice diameter, maximum recommended inlet pressure, serial number, etc.

REGULATOR INSTALLATION

1. Clean the inlet pipe-work to remove any moisture, dirt or debris that could damage the regulator or impair its operation; if possible, it is recommended that a filter be installed upstream of the regulator.
2. Check that the inlet pressure is not beyond the recommended maximum inlet pressure range of the regulator. More specifically, this is determined by the diameter of the orifice fitted in the regulator. This information is stated on the regulator adhesive label or found in the technical brochure published by the manufacturer.
3. Check the regulator for any damage and clean out the regulator body, if necessary.
4. Install the regulator within the pipe-work, using approved pipe sealant on the male pipe threads of the adjoining pipe only. The regulator can be fitted in any position or at any angle but the direction of the main spring will have a small effect on factory setting. In particular, pay specific attention to the following:



- Ensure the “flow directional arrow” marked on the regulator body is in the correct direction or the outlet side will become over-pressurized and damaged.
- There is adequate protection against physical damage while in operation.
- There is sufficient access to the regulator top cap for outlet pressure adjustment. Additionally, regulators with no internal relief valve are incorporated with integral safety slam-shut valve (SSV). There must be sufficient access to the SSV top cap for setting adjustment. Approximately 6” (20 cm) from the SSV top cap to closest surface is recommended.
- Ensure the regulator relief vent is pointing downwards or a fitting is installed to point the termination of the vent downwards. Additionally, there should be a screen fitted at the vent termination. This is to prevent debris, rain or other foreign particles from entering the diaphragm chamber.
- Even though the regulator is installed indoors, the regulator relief vent does not need to be piped away to atmosphere since there is no internal relief valve and there is layers of safety devices to protect against diaphragm rupture and over-pressure conditions.
- The regulator vent should be inspected periodically to ensure it is not blocked.

START-UP PROCEDURE

5. Ensure both inlet and outlet isolation valves are closed. Mount a pressure gauge downstream of the regulator, if one is not already installed to measure downstream pressure.
6. Open the downstream isolation valve slowly. Gradually open inlet isolation valve or introduce inlet pressure. The outlet pressure gauge should read a slightly higher pressure that stated on regulator label.
7. Soap test the regulator and associated piping joints to ensure there is no gas leakages.
8. Introduce a small flow through the regulator by opening a downstream purge valve or allow downstream equipment to demand the supply of gas. With a small flow, ensure the regulator outlet pressure set point is accurate to the application requirement.

ADJUSTING OUTLET PRESSURE

9. Remove the regulator top cap
10. Rotate the outlet pressure set point adjuster clockwise to increase outlet pressure, counterclockwise to decrease outlet pressure to desired level.
11. Once the desired outlet pressure set point is achieved, replace the regulator top cap.

EXTERNAL IMPULSE LINE CONNECTION E.C.L. (optional)

12. If the regulator senses outlet pressure externally or via an external control line, this line will have to be installed before commissioning.
13. The regulator diaphragm casing will have a boss that is drilled and tapped for the installation of an external impulse line. This external control line must be connected from this point to the outlet piping system, a minimum of five times (5X) the diameter of the outlet piping. The control line must be equal or larger than the tapped diameter of the boss.
14. Commissioning is completed the same as an internally control or impulse regulator but leakage or soap test must be completed on the control line once commissioned.

SAFETY SLAM-SHUT COMMISSIONING INSTRUCTIONS

**Since this regulator does not have an internal relief valve, there will an incorporated integral safety slam-shut valve. Commissioning, installation and setting instructions will be found on a separate specific sheet enclosed in the shipped package.

REMARKS**THIS REGULATOR SHOULD ONLY BE INSTALLED, COMMISSIONED AND ADJUSTED BY A LICENSED GAS FITTER. INSTALLATION MUST MEET ALL LOCAL REQUIREMENTS, CODES AND REGULATIONS.

BRYAN DONKIN RMG CANADA LIMITED

P.O.Box 1616, 50 Clarke Street South, Woodstock, Ontario, Canada N4S 0A8

Website: www.rmg.com Email: ms2@brmgcanada.com



Installation & Commissioning Instructions

Product: SAFETY SLAM-SHUT VALVES (OPCO or UPCO/OPCO)

Data Sheet No: CIC 9002A

Issue Date: October 2006

GENERAL INFORMATION

EQUIPMENT DIAGRAM AND LABELLING

Model 290-OPCO

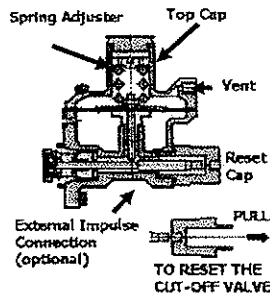

Model 309-OPCO or 309-UPCO/OPCO

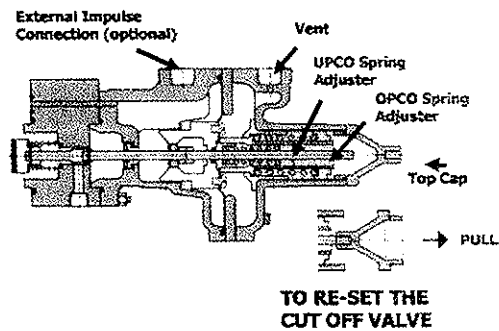

- Technical information will be found on the adhesive label or metal badge on the main spring housing of the diaphragm casing
- Information - model number, factory cut-off pressure setting, factory relief valve setting, orifice diameter, maximum recommended inlet pressure, serial number, etc.
- The safety slam-shut valve can be associated with a pressure regulator or can be independent on it's own body

INSTALLATION

1. Clean the inlet pipe-work to remove any moisture, dirt or debris that could damage the equipment or impair its operation; if possible, it is recommended that a filter be installed upstream of the equipment.
2. Check that the inlet pressure is not beyond the recommended maximum inlet pressure range of the safety device. This information is stated on the regulator or on the safety device adhesive label or found in the technical brochure published by the manufacturer.
3. Check the safety device for any damage and clean out the body, if necessary.
4. Install the equipment within the pipe-work, using approved pipe sealant on the male pipe threads of the adjoining pipe only. The safety valve can be fitted in any position or at any angle but the direction of the main spring will have a small effect on factory setting. In particular, pay specific attention to the following:
 - Ensure the "flow directional arrow" marked on the body is in the correct direction or the outlet side will become over-pressurized and damaged.
 - There is adequate protection against physical damage while in operation.
 - There is sufficient access to the top cap for cut-off pressure adjustment and to reset the valve. A minimum of 6" or 15 cm is recommended between top cap and closest surface.
 - Ensure the vent is pointing downwards or a fitting is installed to point the termination of the vent downwards to prevent debris, rain or other foreign particles from entering the diaphragm chamber.



- If the equipment is installed outdoors, ensure that the vent terminates or exit at a safe location. For example, away from windows, vents or sources of ignition. Refer to local codes or safety regulations for these distances. The safety device vent does not relief gas unless there is damage or rupture to the diaphragm.
- If the equipment is installed indoors, ensure the vent is piped away to atmosphere or a safe location with piping that has a diameter equal or larger than the vent. This is not required if the equipment is an approved model to be installed indoors without requirement of vent line to atmosphere (i.e. SD or safety diaphragm).
- The vent should be inspected periodically to ensure it is not blocked.

START-UP PROCEDURE for Safety Device with Over Pressure Cut-Off (OPCO) only

5. Ensure both inlet and outlet isolation valves are closed. If safety device is incorporated with a regulator, refer to regulator start-up procedure as well. The safety device should be found in the "open position" and no adjustment should be required to settings.
6. Open the downstream isolation valve slowly. Gradually open inlet isolation valve or introduce inlet pressure. The outlet pressure gauge should read the desired pressure. If there is no pressure reading the safety valve is in the closed position. Refer to reset procedure below. If the safety device is independent (without regulator) there will be some pressure drop across the valve.
7. Soap test the safety device and associated piping joints to ensure there is no gas leakages.

START-UP PROCEDURE for Safety Device with Under and Over Pressure Cut-Off (UPCO/OPCO)

8. Ensure both inlet and outlet isolation valves are closed. If safety device is incorporated with a regulator, refer to regulator start-up procedure as well. The safety device should be found in the "closed position" since the under pressure setting is tripped because the valve is not pressurized. No adjustment to setting should be required.
9. Open the downstream isolation valve slowly. Remove the top cap or reset cap, reverse and thread onto the reset spindle. Pull back on the reset cap attached to the spindle while gradually opening the inlet isolation valve or introducing inlet pressure. As the valve pressurizes, the safety valve will latch and then you can release the reset cap and replace to original position. If the safety device is independent (without regulator) there will be some pressure drop across the valve.
10. Soap test the safety device and associated piping joints to ensure there is no gas leakages.

ADJUSTING CUT-OFF OR TRIP PRESSURES

11. Remove the regulator top cap.
12. Rotate the desired set point adjuster clockwise to increase cut-off pressure, counterclockwise to decrease cut-off pressure to desired level.
13. Normally, the safety cut-off pressure set points or levels should be pre-set at the factory during initial testing.
14. Once the desired levels of cut-off pressures are achieved, replace the top cap.

RESET PROCEDURES

- refer to equipment diagram and labeling for visual instruction. Remove reset cap, reverse and thread onto exposed spindle. Pull back on cap attached to spindle to re-latch or engage valve. For safety valve with UPCO, refer to start up procedure since valve needs to be pressurized before reengagement due to under pressure protection feature.

EXTERNAL IMPULSE LINE CONNECTION E.C.L. (optional)

15. If the safety valve senses outlet pressure externally or via an external control line, this line will have to be installed before commissioning.
16. The diaphragm casing will have a boss that is drilled and tapped for the installation of an external impulse line. This external control line must be connected from this point to the outlet piping system, a minimum of five times (5X) the diameter of the outlet piping. The control line must be equal or larger than the tapped diameter of the boss.
17. Commissioning is completed the same as an internally control or impulse regulator but leakage or soap test must be completed on the control line once commissioned.

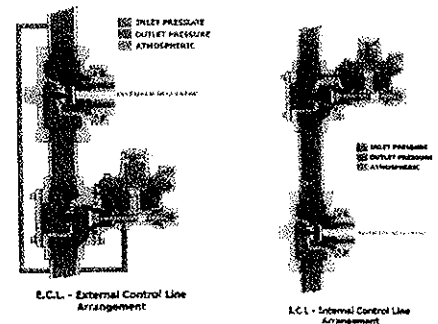

REMARKS

****THIS VALVE SHOULD ONLY BE INSTALLED, COMMISSIONED AND ADJUSTED BY A LICENSED GAS FITTER. INSTALLATION MUST MEET ALL LOCAL REQUIREMENTS, CODES AND REGULATIONS.**